

# Automotive Selection Guide

TVS & ESD / Diode Rectifier / Zener / MOSFET / BJT / FRED / SiC

*AEC-Q101 Qualified*



# CONTENT

- **Company Profile**
  - Automotive Application
- **Automotive ECU Load Dump Protection**
  - Testing criteria standard
  - Power line conduction and coupling surge protection
  - Data radiation and coupling line surge protection
  - Anti-reverse diode IFSM selection evaluation
  - Related product development plan
- **Automotive Solutions**
  - Motor control
  - LED Lighting
  - Electronic horn
  - USB Charger **New**
  - Wireless Charging Transmitter **New**
- **xEV Application**
  - BMS (Battery Management System)
  - xEV Charging Station
  - OBC (On Board Charger)
- **Quality Control for Automotive**

## Company profile

PANJIT International Inc. is a leading global manufacturer dedicating in supplying high quality semiconductor discrete, serving the consumer, power supply, industrial, automotive, communication and computing segments.

✓ **Founded in: 1986**

✓ **TWSE: 2000(IPO)**

✓ **Approximately: 3,300 employees worldwide**

✓ **2021 revenue: US\$ 457M**





# Automotive Application

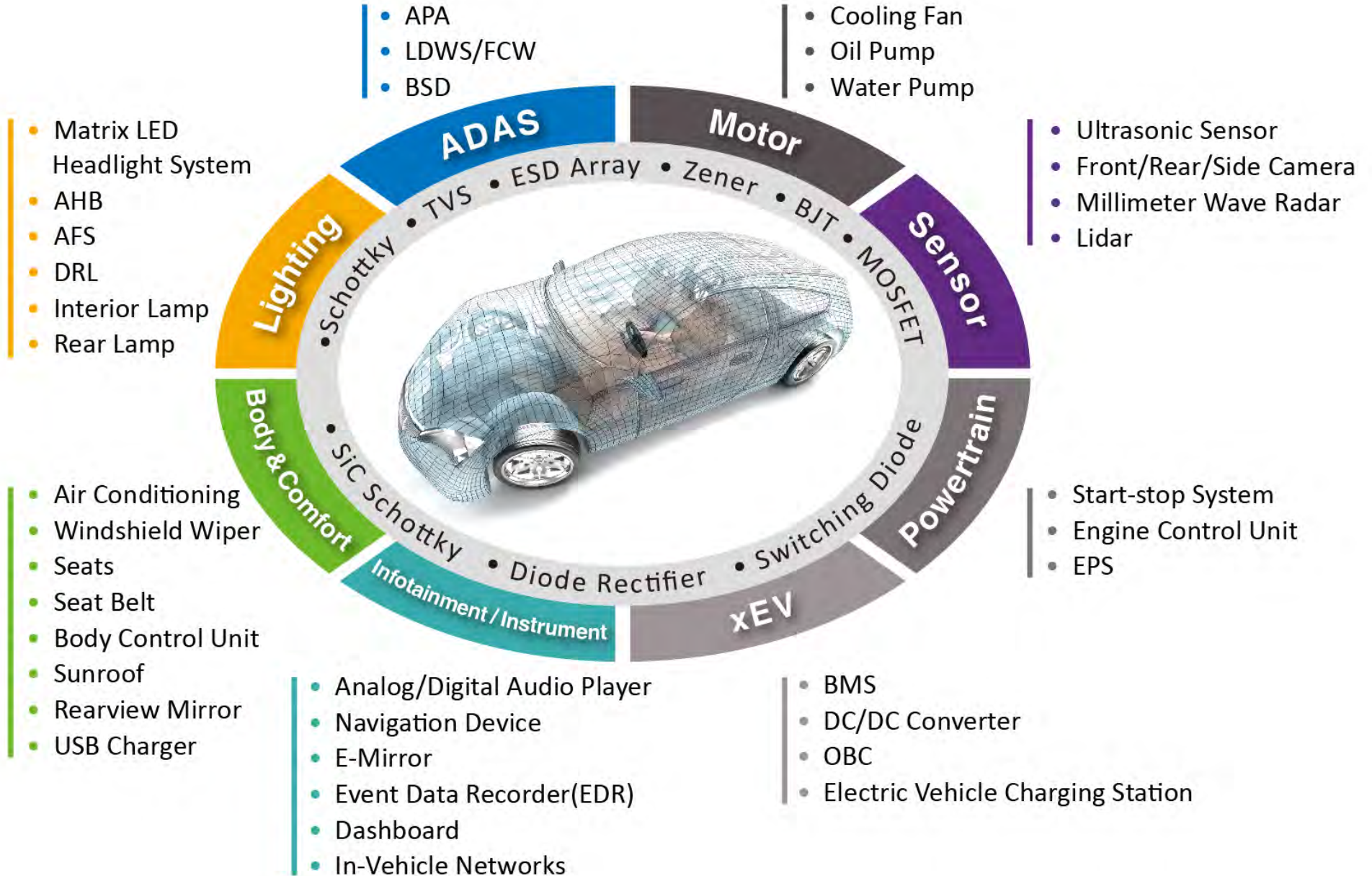



# Automotive ECU Load Dump Protection

ISO 7637-2 / ISO 16750-2 / ISO 10605

- Testing criteria Standard
- Power line conduction and coupling surge protection
- Data radiation and coupling line surge protection
- Anti-reverse diode IFSM selection evaluation
- Related product development plan



# Where does Automotive Transients Come From?

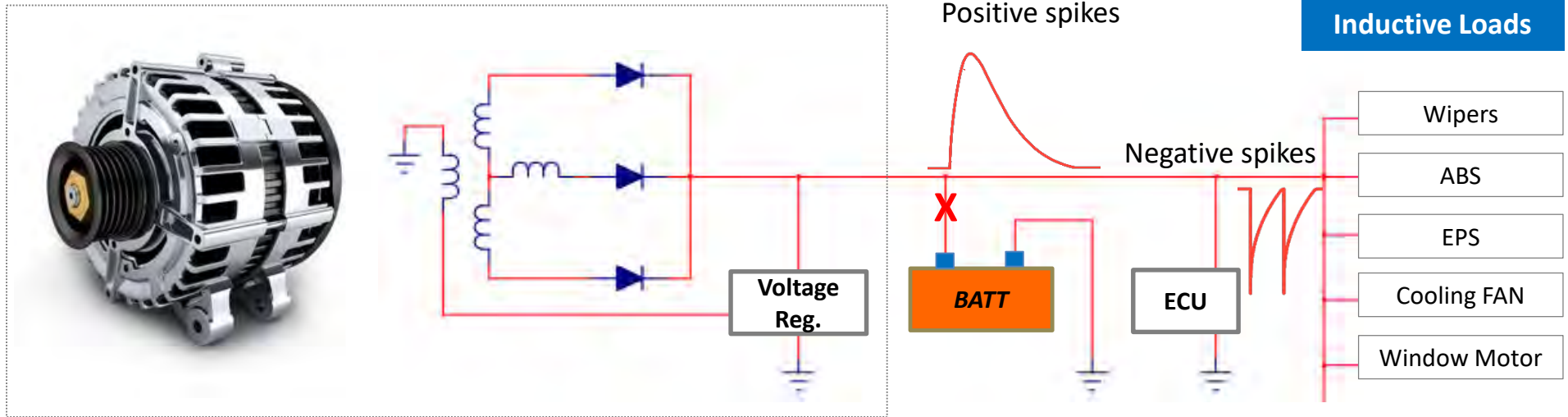

## Power Line Transient Surge Wave

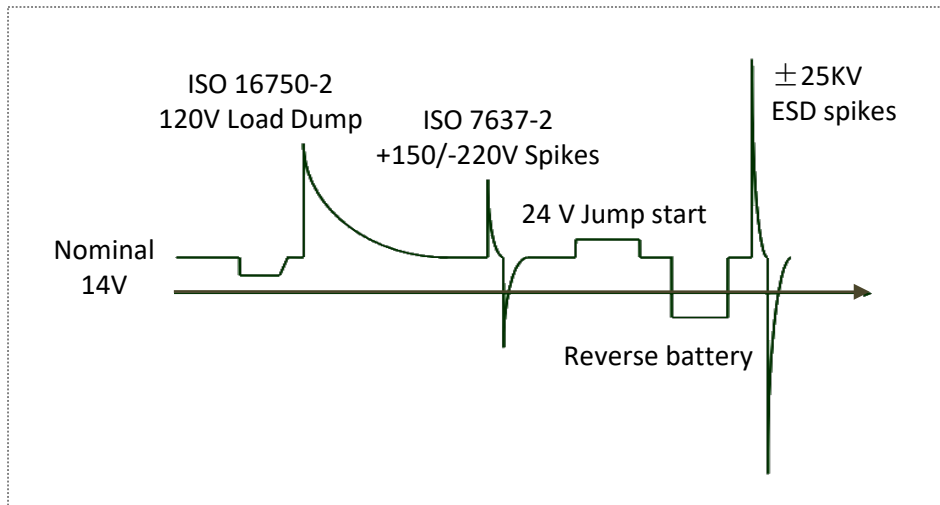

## Data Line Transient Surge Wave

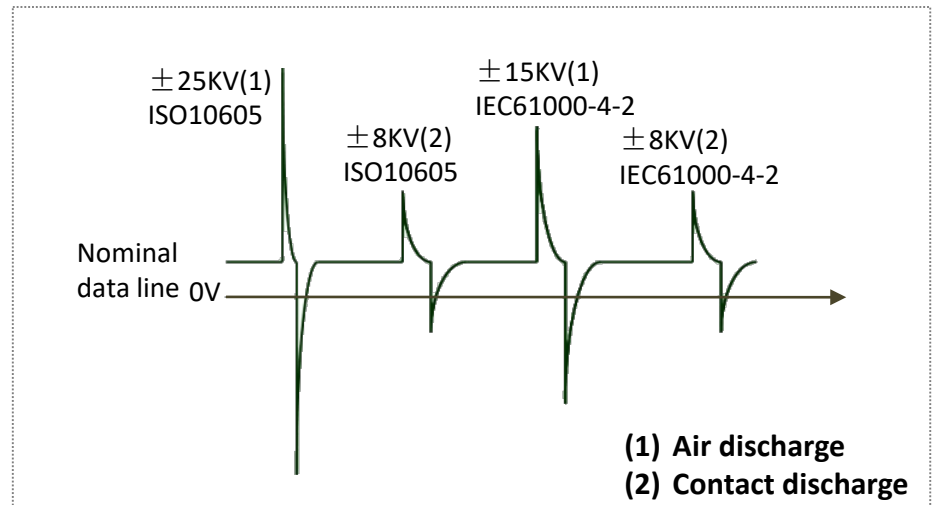

# Testing Criteria Standard

## Related standards overview

Category	Standard types	Standard Number	Standard Titles
Electrical Loads	ISO	ISO 16750-2	Road vehicles -- Environmental conditions and testing for electrical and electronic equipment — Part 2: Electrical loads
	ISO	ISO 21848	Road vehicles -- Electrical and electronic equipment for a supply voltage of 42 V — Electrical loads
Electrical disturbances from conduction and coupling	ISO	ISO 7637-2	Road vehicles -- Electrical disturbances from conduction and coupling — Part 2 : Electrical transient conduction along supply lines only
	ISO	ISO 7637-3	Road vehicles -- Electrical disturbances from conduction and coupling — Part 3 : Electrical transient transmission by capacitive and inductive coupling via lines other than supply lines
ESD	ISO	ISO 10605	Road vehicles -- Test methods for electrical disturbances from electrostatic discharge

# Power Line Conduction and Coupling Surge Protection

## TVS and diode solutions

- The transient surge on power line is caused by sudden pulse of high energy transient, related standards including ISO 7637-2, ISO 16750-2, JSAO D-001 : 94.
- The transient surge on data line is mainly from high energy pulse during the operation of vehicle, mostly because of the ESD parts, related standards are ISO 7637-3, ISO 10605, IEC61000-4-2

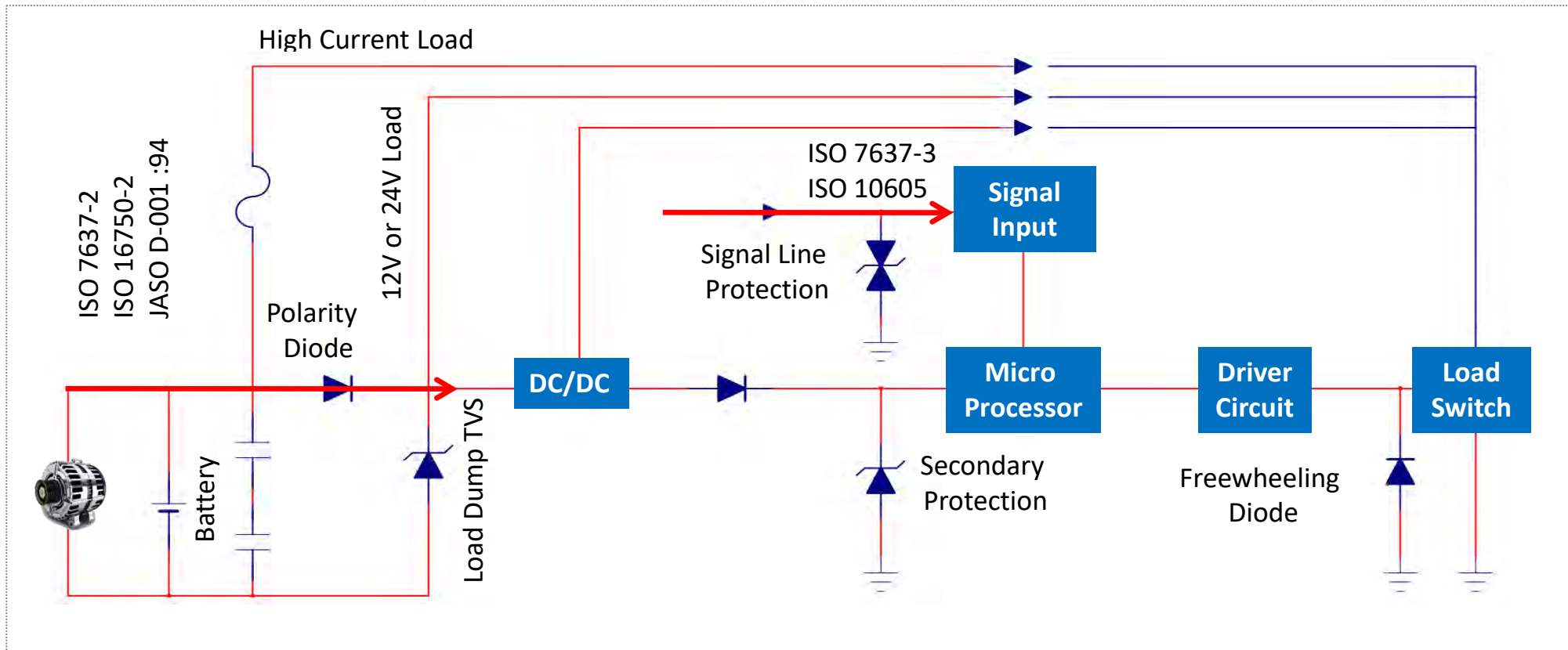



# Automotive Environment Test Levels

## Power line specified in ISO 7637-2 2011(E) and ISO 16750-2

Test Pulse	12V System		24V System		Min. number of pulses or test time
	Test pulse severity level $U_s(V)$		Test pulse severity level $U_s(V)$		
	IV	III	IV	III	
1	-150	-112	-600	-450	500 pulses
2a	+112	+55	+112	+55	500 pulses
2b	+10	+10	+20	+20	10 pulses
3a	-220	-165	-300	-220	1h
3b	+150	+112	+300	+220	1h
4	6.5	5	--	10	1 pulse
5a	87V/Ri=0.5Ω/t <sub>d</sub> =400mS	65V/Ri=4Ω/t <sub>d</sub> =40mS	173V/Ri=1Ω/t <sub>d</sub> =350mS	123V/Ri=8ΩS/t <sub>d</sub> =100mS	10 pulses
5b	40V/Ri=0.5Ω/t <sub>d</sub> =400mS	30V/Ri=4Ω/t <sub>d</sub> =40mS	50V/Ri=1Ω/t <sub>d</sub> =350mS	50V/Ri=8ΩS/t <sub>d</sub> =100mS	10 pulses

- The test Pulse 4, 5a, and 5b have been removed from ISO 7637-2-2011, since they are specified in ISO 16750-2 2010 and ISO 21848.

# Power Line Transient Surge Protection

## Reverse battery protection

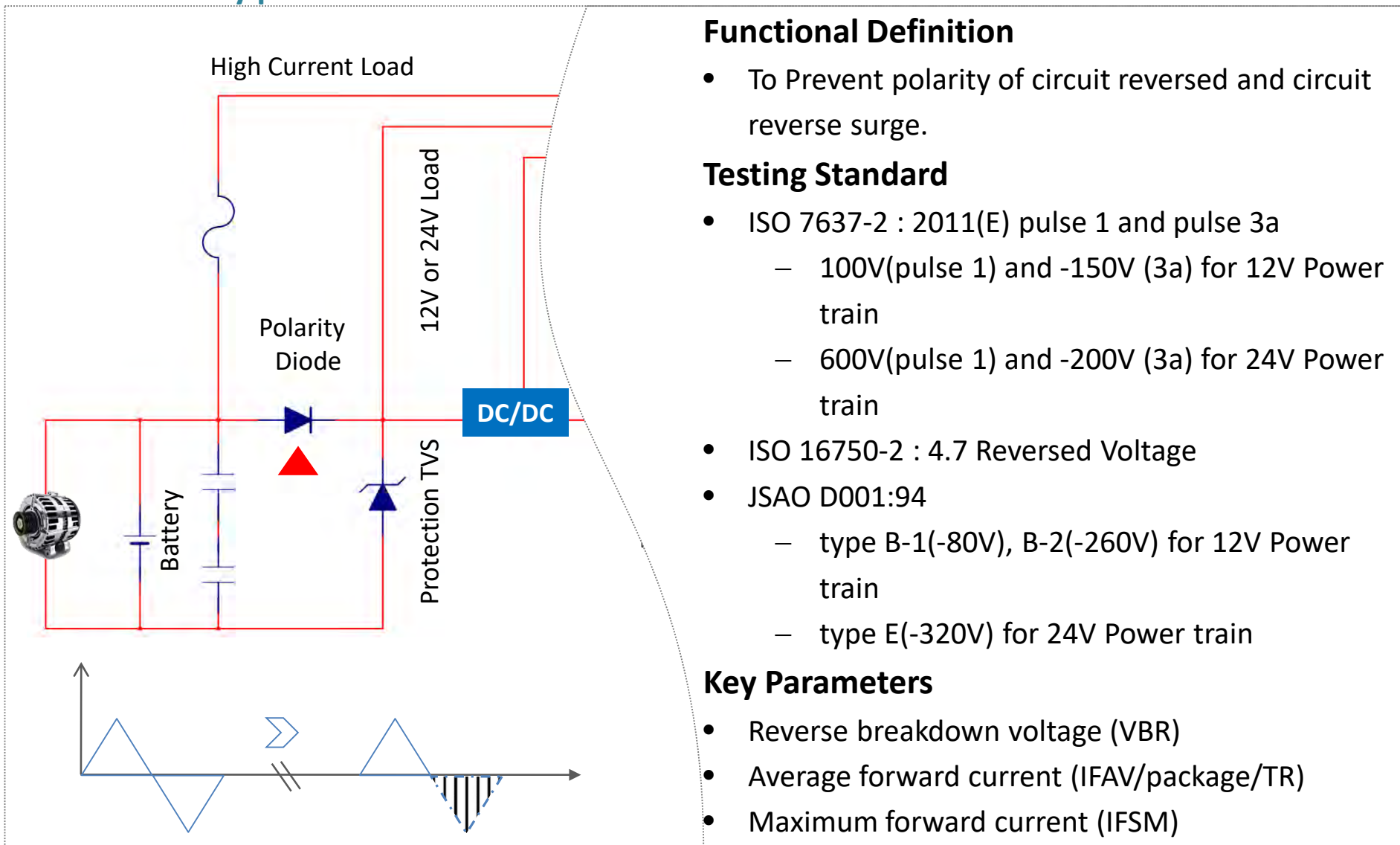

### Functional Definition

- To Prevent polarity of circuit reversed and circuit reverse surge.

### Testing Standard

- ISO 7637-2 : 2011(E) pulse 1 and pulse 3a
  - 100V(pulse 1) and -150V (3a) for 12V Power train
  - 600V(pulse 1) and -200V (3a) for 24V Power train
- ISO 16750-2 : 4.7 Reversed Voltage
- JSAO D001:94
  - type B-1(-80V), B-2(-260V) for 12V Power train
  - type E(-320V) for 24V Power train

### Key Parameters

- Reverse breakdown voltage (VBR)
- Average forward current (IFAV/package/TR)
- Maximum forward current (IFSM)



# Reverse Battery Protection with General Rectifier

## Polarity diode connection type

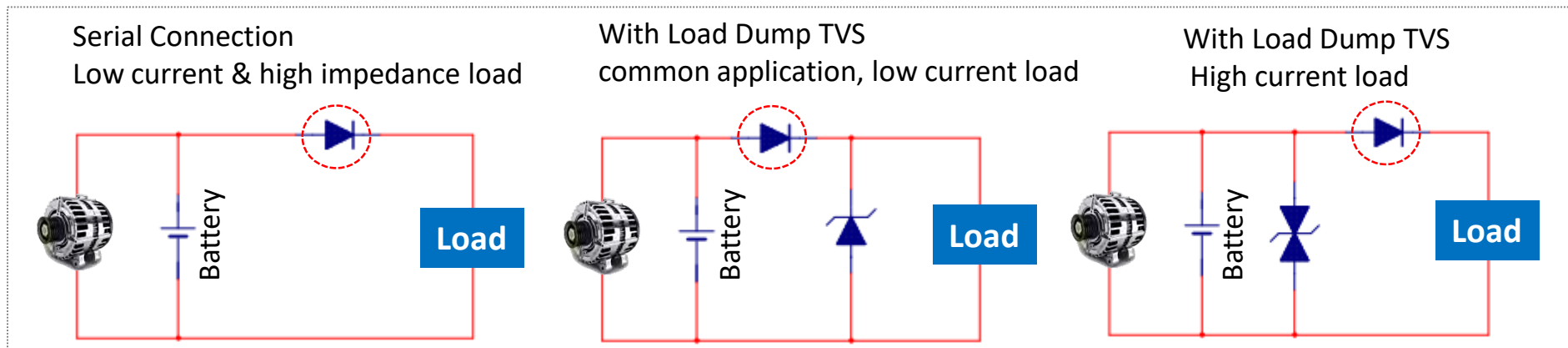

## Recommended General Purpose Rectifiers



Package	Current				
	1A	2A	3A	5A	8A
SOD-123FL/HE	GS1010FL-AU				
SMA	GS1M-AU				
SMB	S2M-AU				
SMC			S3M-AU	S5M-AU	S8M-AU

# Reverse Battery Protection with Schottky Rectifier

High Performance Schottky has lower VF, it can replace standard rectifiers to reduce power loss in high current application. By different application and its standard, it is recommended to use the Schottky between 60V-100V and combine with the circuit on the right to assure the ISO 7637-2 test pulse 1 and pulse 3a will comply with breakdown voltage of the Schottky.

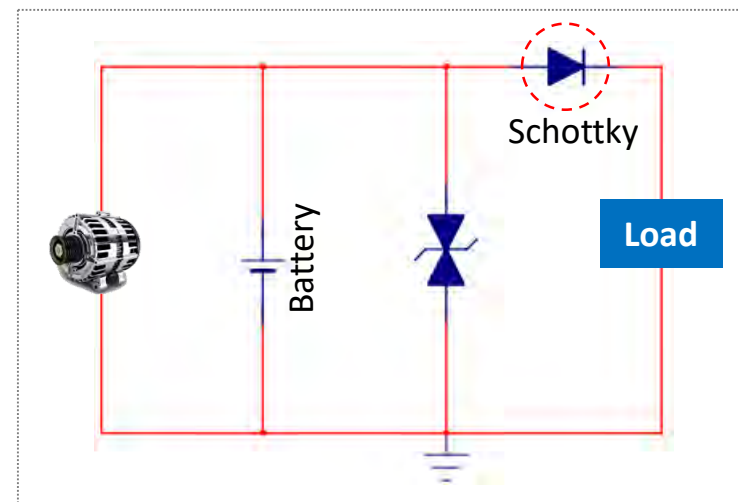

## Recommended Power Schottky

Wafer Technology	Package	Current			
		2A	3A	5A	8A
Planar	SMA	BR210-AU			
	SMB		BR310-AU		
	SMC		MB310-AU	MB510-AU	*MB810

\*AEC-Q101 In development



# Planar MOS Schottky Advantage

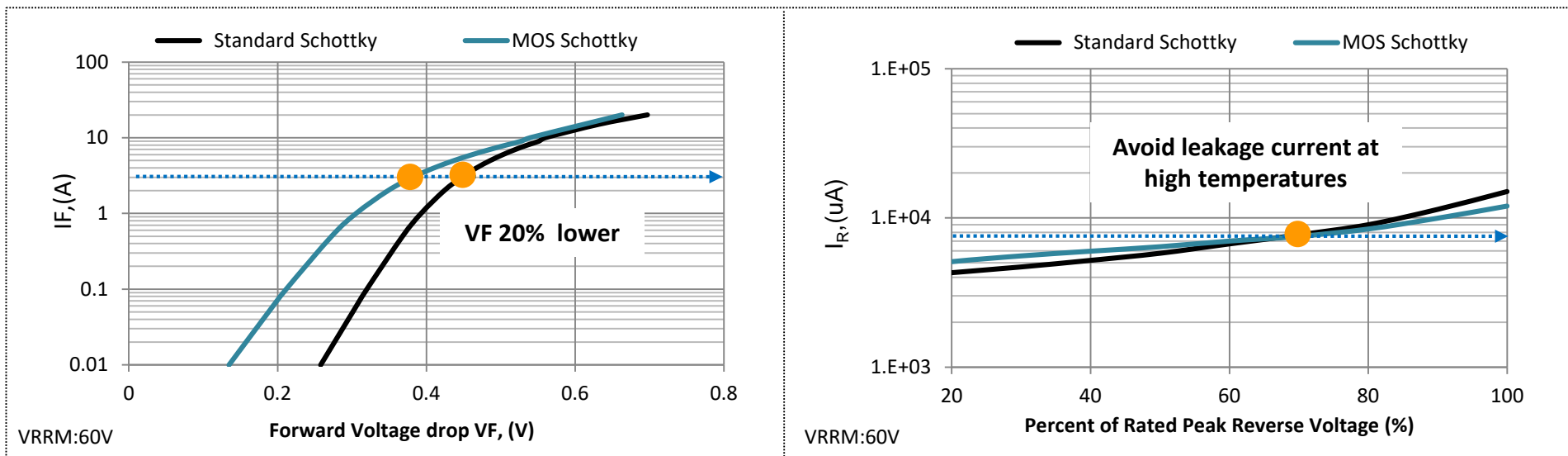

	DFN2L	SOD-323	SOD-323HE	SOD-123	SOD-123FL	SOD-123HE	SMAF-C	SMBF
$I_{F_{AV}}$								
0.5A	●							
1A		●	●	●				
2A			●	●	●	●		
3A					●	●	●	
5A							●	●
8A								●
10A								
15A								
Series	SBAxxQ-AU	SBAxxCS-AU	SBAxxCH-AU	SBAxxAS-AU	SBAxxAL-AU	SBAxxAH-AU	SBAxxAFC-AU	SRMxxF-AU

Annotations: 20V to 40V (orange oval), 40V to 60V (purple oval)

# Schottky Rectifier Technology Evolution

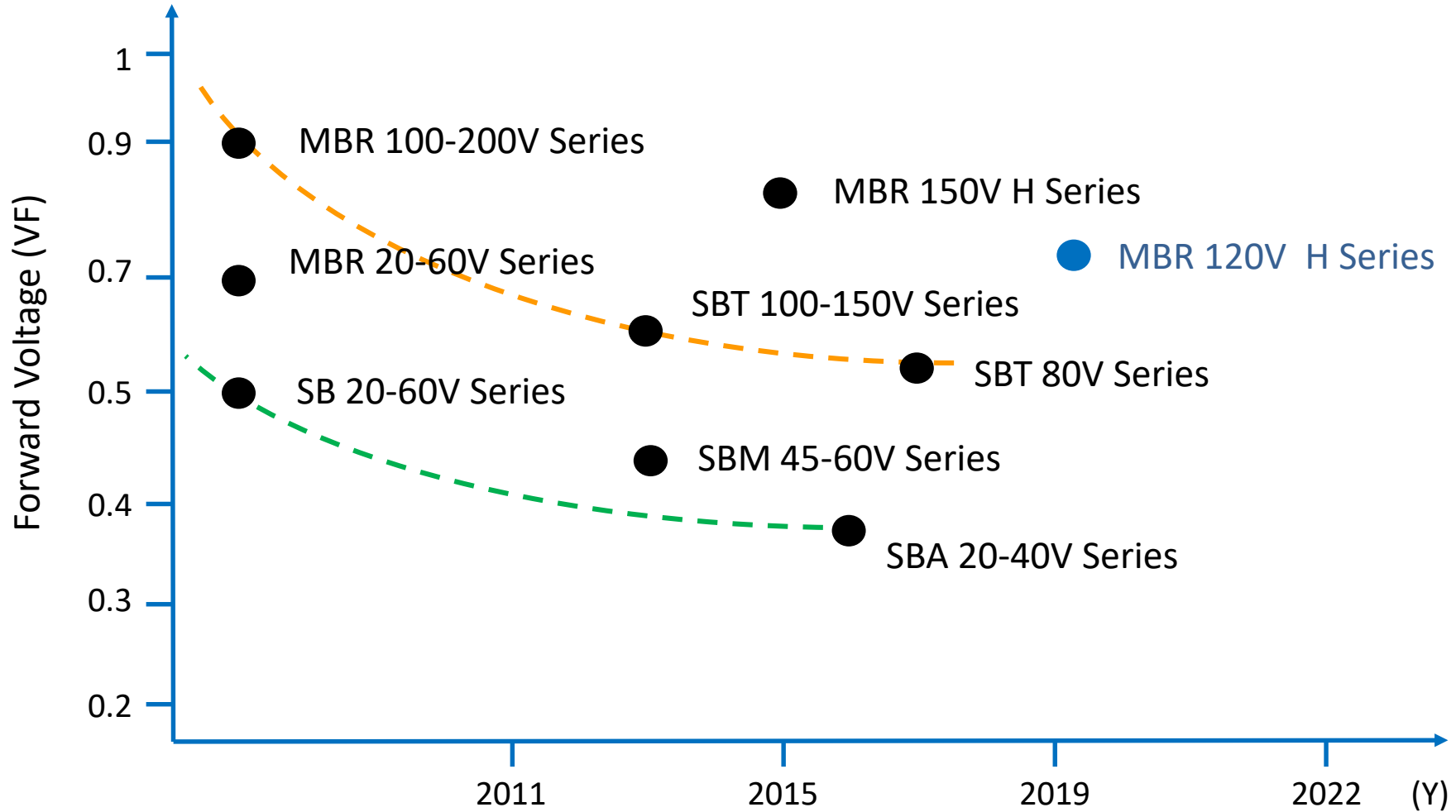



# Reverse Battery Protection with MOSFET

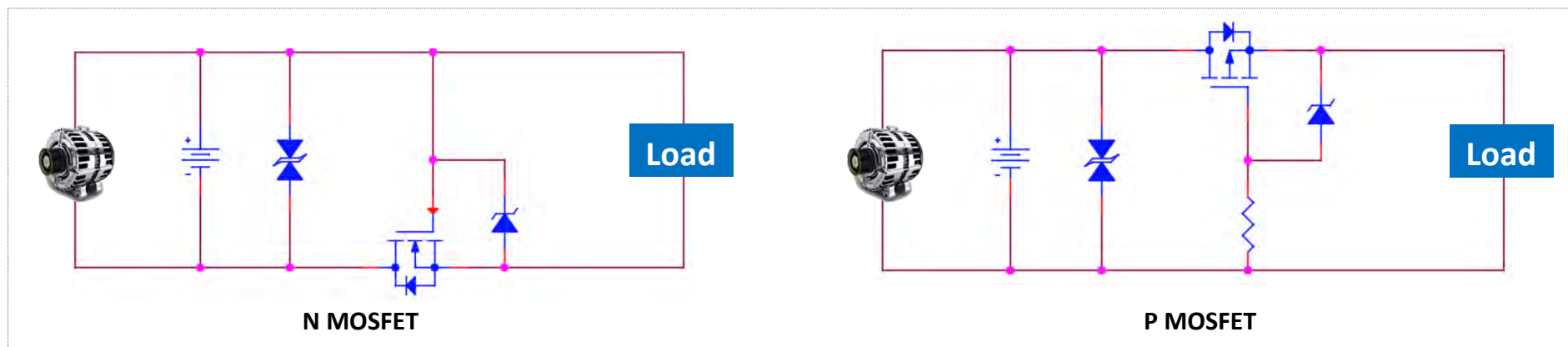

- Standard diode has high VF at high power application. It will cause power loss and rise in case during reverse blocking in the applications. This issue can be solved by using MOSFET, as it's  $R_{DS(ON)}$  is far lower than VF.
- N-MOS has lower  $R_{DS(ON)}$  when compared to P-MOS at same chip size, however N-MOS control circuit is much simpler.
- It is suggested to use 60V to 100V as reversed MOSFET and make sure it's working within SOA. Put Load Dump TVS at front and combine with Bi-directional TVS, thus the transient voltage surge will not be higher than  $V_{DS}$  of MOSFET.

## Recommend MV MOSFET

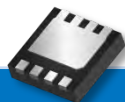
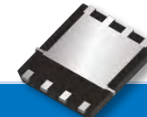
$V_{DS}$	$V_{GS}$	Ch.	$R_{DS(ON)}$ 10V	$R_{DS(ON)}$ 4.5V			
V	V	N/P	( mΩ ) max.		TO-252AA	DFN3333-8L	DFN5060-8L
-60	20	P	48	65	PJD16P06A-AU	PJQ4463AP-AU	PJQ5463A-AU
-60	20	P	68	85	PJD15P06A-AU		PJQ5465A-AU
60	20	N	12	15	PJD45N06A-AU		PJQ5462A-AU
60	20	N	17	20	PJD40N06A-AU	PJQ4464AP-AU	PJQ5466A1-AU
100	20	N	25	28.5	PJD50N10AL-AU		PJQ5476AL-AU

# Power Line Transient Surge Protection

## Definition

- To control the transient surge on power line/cable of the vehicle to protect the module.

## Test standard

- ISO 7637-2, ISO16750-2, ISO 21848, JSO D001 : 94

## Key parameter

- Max  $P_{pp}$  and Max  $I_{pp}$
- Safety threshold voltage  $V_{RWM}$
- Clamping voltage  $V_C$

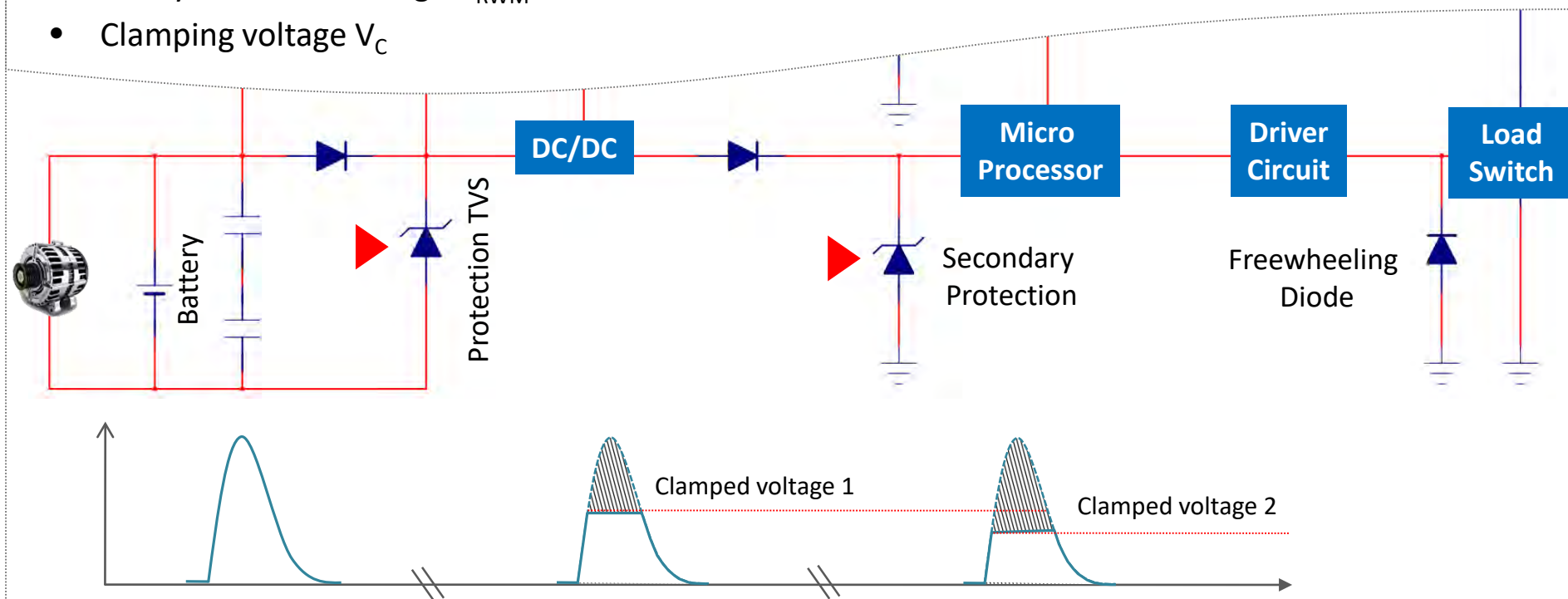



# Power Line Transient Surge Protection

## Two types of TVS Protection

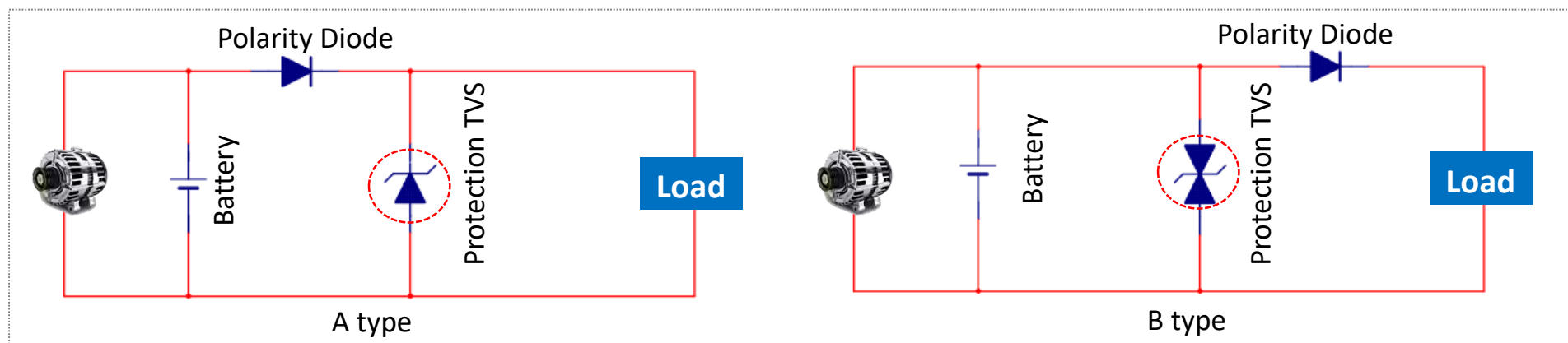

- TVS Connection Type (A type & B type)**
  - ✓ Base on customer design to choose unidirectional and Bi-directional TVS
  - ✓ B-type is suggested to adopt Bi-directional TVS protection due to high current has normal load condition and high current load.

- TVS Key parameter**
  - ✓  **$V_c$  (Clamping voltage)**  
Maximum clamping voltage of TVS must lower than the maximum withstand voltage of electronic module in order to make sure protection devices will not be damage in high surge and Load Dump test process.
  - ✓  **$V_{RWM}$  (Stand-off voltage )**  
 $V_{RWM} \geq$  system Max working voltage to avoid TVS incorrect action, meanwhile combine test status to pick  $V_c$  &  $I_{pp}$  parameter.

System $U_N$	12V	24V
Recommend TVS $V_{RWM}$	22V/24V/27V	30V/33V/36V

# Automotive Power TVS

## For ISO 7637-2 pulse 1 to pulse 3b Transients Protection

TVS series	Package	UNI / BI	P <sub>D</sub> (W)	12V System Level IV (V)					24V System Level IV (V)					
				1	2a	2b	3a	3b	1	2a	2b	3a	3b	
				-150	+112	+10	-220	+150	-600	+112	+20	-300	+300	
P4FLxxA-AU	SOD-123FL	UNI	400	pass	pass	pass	pass	pass	pass	pass	pass	pass	pass	pass
P4SMAJxxA-AU	SMA	UNI & BI	400	pass	pass	pass	pass	pass	pass	pass	pass	pass	pass	pass
P6AFCxxA-AU	SMAF-C	UNI	600	pass	pass	pass	pass	pass	pass	pass	pass	pass	pass	pass
P6SMBJxxA-AU	SMB	UNI & BI	600	pass	pass	pass	pass	pass	pass	pass	pass	pass	pass	pass
P6KExxA-AU	DO-15	UNI & BI	600	pass	pass	pass	pass	pass	pass	pass	pass	pass	pass	pass
1.5SMCJxxA-AU	SMC	UNI & BI	1500	pass	pass	pass	pass	pass	pass	pass	pass	pass	pass	pass

- Pulse 1 and Pulse 3a are negative inrush current. The unidirectional TVS will be in a forward condition during the surge if the circuit is not equipped with a reversed Diodes. The continuous high current will cause the thermal breakdown of TVS; hence, it is suggested to adopt above 600W TVS or Bi-directional TVS if there is no reversed diodes.

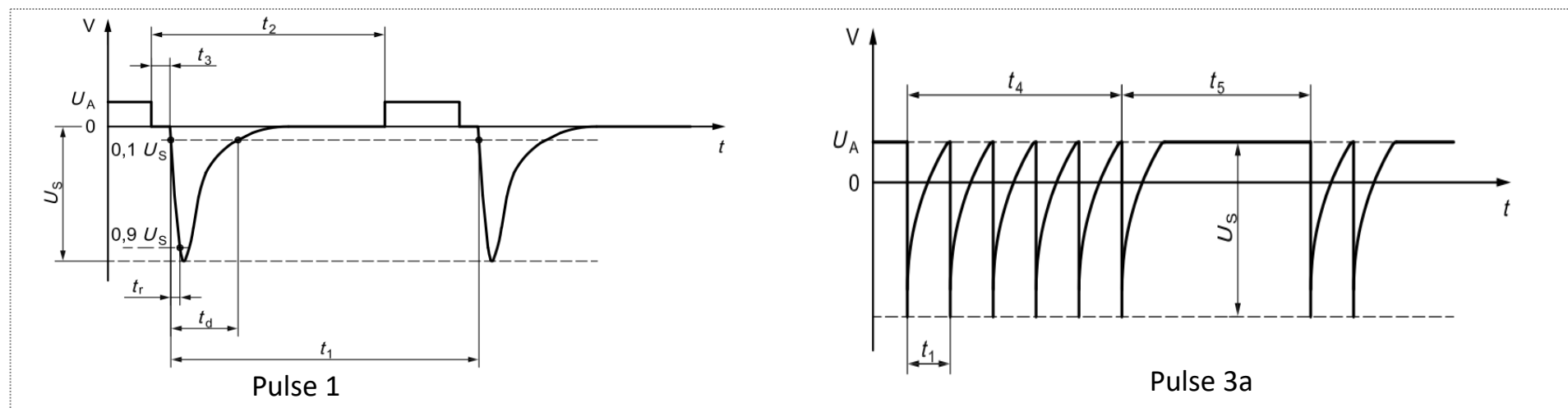

# Automotive Power TVS

## For ISO 7637-2 & ISO 16750-2 pulse 5a Load Dump Protection



Parameter	Type of System		ISO 16750-2	ISO 7637-2
	$U_N=12V$	$U_N=24V$	Pulses	Pulses
$U_S$ (V)	$79 \leq U_S \leq 101$	$151 \leq U_S \leq 202$		
$R_i$ ( $\Omega$ )	$0.5 \leq R_i \leq 4$	$1 \leq R_i \leq 8$	10 Pulses at intervals of 1min	1Pulse
$t_d$ (mS)	$40 \leq U_S \leq 400$	$100 \leq U_S \leq 350$		
$t_r$ (mS)	10 (+0/-5)	10 (+0/-5)		

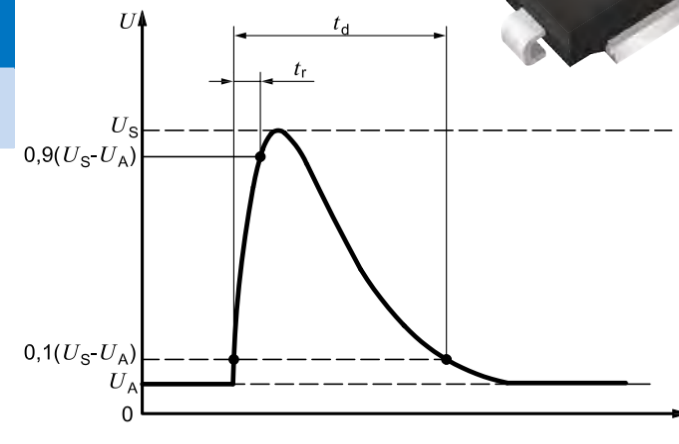

ISO 16750-2 2010 Test pulse a

- ISO 16750-2 pulse a replaces ISO 7637-2 (2004) pulse 5a
- Compared to ISO 7637-2 (2004) 5a, the testing condition of ISO 16750-2 pulse a is more abstract; the pulse test time is from 1 time to 10 times in 10 minutes. The request of test condition is Load Dump protection and reversed protection devices can withstand higher current surge.
- Due to continuous high reversed current surge, Load Dump protection and reversed protection devices should have higher capacity of withstanding high junction temperature.
- $I_{pp}$  decided by  $V_C$  and test  $R_i$  :  $I_{clamping} = (U_S - V_{clamping}) / R_i$
- For pulse 5a, it is suggested to select PANJIT's DO-218AB high power package: SM8SxxA-AU, SM6SxxA-AU, SM5SxxA-AU series products.



# SMxSxxA-AU Load Dump TVS

## In ISO 16750-2 5a Load Dump Surge Test

12V System SM5S24A-AU

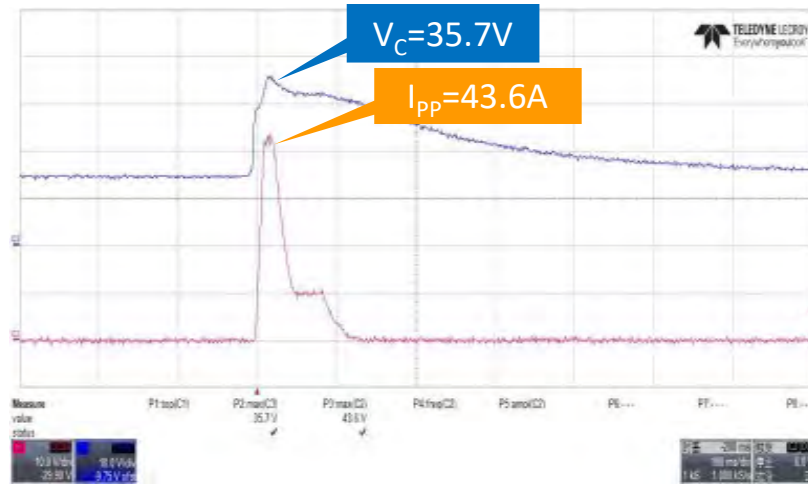

Test Condition  $U_N = 12V$   $R_i = 0.5\Omega$   $U_S = 101V$   $t_d = 400ms$

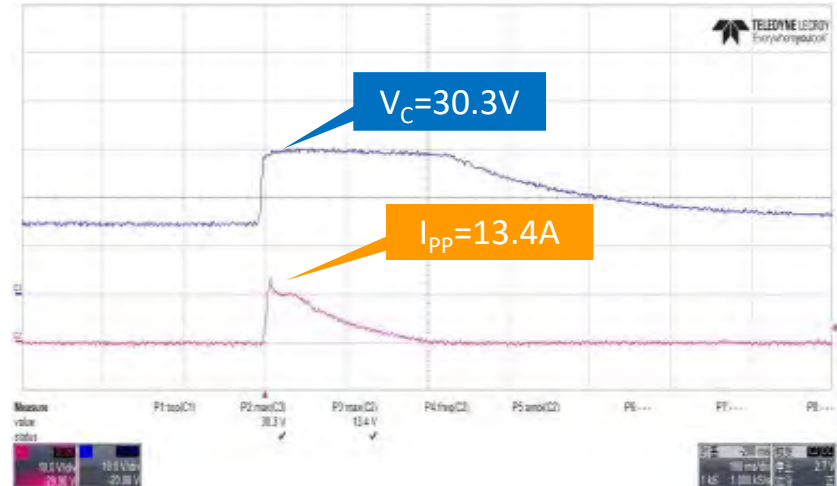

Test Condition  $U_N = 12V$   $R_i = 5\Omega$   $U_S = 101V$   $t_d = 400ms$

24V System SM8S36A-AU

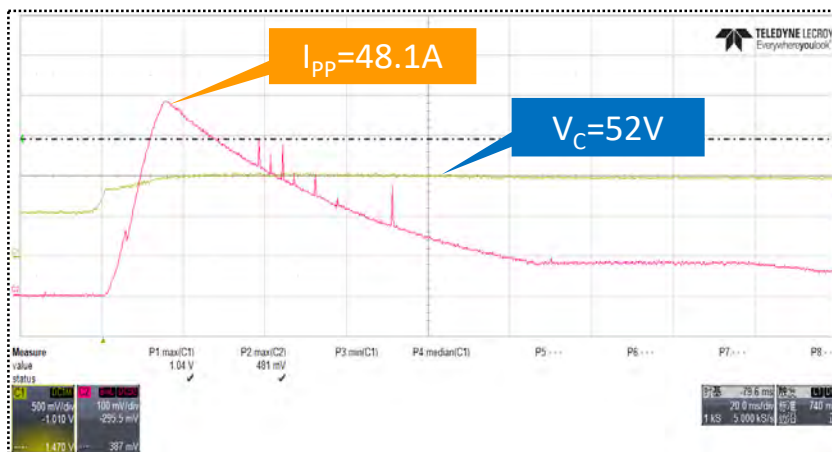

Test Condition  $U_N = 24V$   $R_i = 3\Omega$   $U_S = 202V$   $t_d = 400ms$

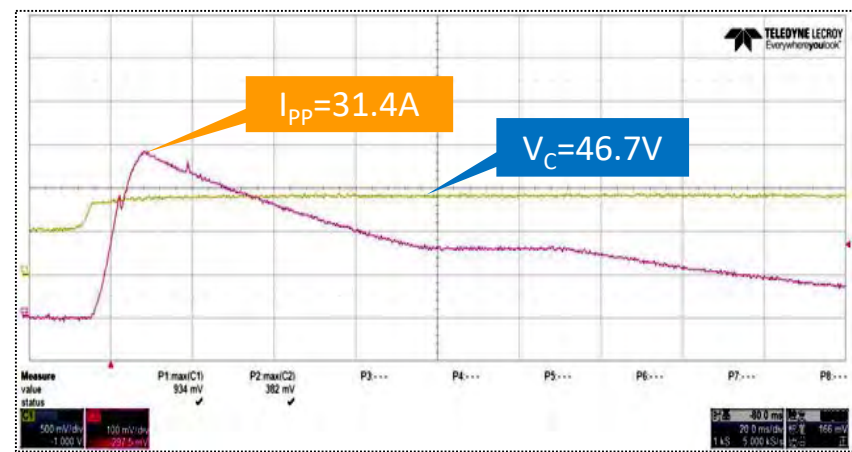

Test Condition  $U_N = 24V$   $R_i = 8\Omega$   $U_S = 202V$   $t_d = 400ms$

# SMxSxxA-AU Load Dump TVS Series

PANJIT offers 3 series Load Dump TVS: SM5SxxxA-AU/SM6SxxxA-AU/SM8SxxxA-AU, the highest power absorption is 3600W, 4600W, 6600W respectively and the  $V_{RWM}$  range is from 14V to 48V. These 3 series TVS are mainly for the Load Dump protection of 12V and 24V automotive.

Part Number	$P_D$ (W)	$V_{RWM}$ (V)	$V_{BR}@I_T$		$I_T$ (mA)	$I_R@V_{RWM}$	$V_C@I_{PP}$	$I_{PP}$	Application $V_N$ (V)
			Min.	Max.					
SM5S20A-AU	3600	20	22.2	24.5	5	0.5	32.4	111	12
SM5S22A-AU	3600	22	24.4	26.9	5	0.5	35.5	101	12
SM5S24A-AU	3600	24	26.7	29.5	5	0.5	38.9	93	12
SM5S30A-AU	3600	30	33.3	36.8	5	0.5	48.4	74	24
SM5S33A-AU	3600	33	36.7	40.6	5	0.5	53.3	68	24
SM5S36A-AU	3600	36	40	44.2	5	0.5	58.1	62	24
SM6S20A-AU	4600	20	22.2	24.5	5	0.5	32.4	142	12
SM6S22A-AU	4600	22	24.4	26.9	5	0.5	35.5	130	12
SM6S24A-AU	4600	24	26.7	29.5	5	0.5	38.9	118	12
SM6S30A-AU	4600	30	33.3	36.8	5	0.5	48.4	95	24
SM6S33A-AU	4600	33	36.7	40.6	5	0.5	53.3	86	24
SM6S36A-AU	4600	36	40	44.2	5	0.5	58.1	79	24
SM8S20A-AU	6600	20	22.2	24.5	5	0.5	32.4	204	12
SM8S22A-AU	6600	22	24.4	26.9	5	0.5	35.5	186	12
SM8S24A-AU	6600	24	26.7	29.5	5	0.5	38.9	170	12
SM8S30A-AU	6600	30	33.3	36.8	5	0.5	48.4	136	24
SM8S33A-AU	6600	33	36.7	40.6	5	0.5	53.3	124	24
SM8S36A-AU	6600	36	40	44.2	5	0.5	58.1	114	24

## Load Dump TVS PCB Layout Advice

- Lay the TVS close to the power insert port to reduce induction effect and to improve TVS response speed
- Sensitive components are suggested to be placed away from the Load Dump TVS and power insert port, this could effectively reduce surge impact.
- PCB pad layout must match the pad size of DO-218AB package, once the heat sink is fully **soldered** with the PCB pad, the thermal resistance between the TVS and PCB will be reduced.
- **The heat dissipation in which the TVS clamps is mainly dissipated through the PCB. Thus the TVS heat dissipation capability could be improved if the unused area of the PCB are utilized efficiently.**

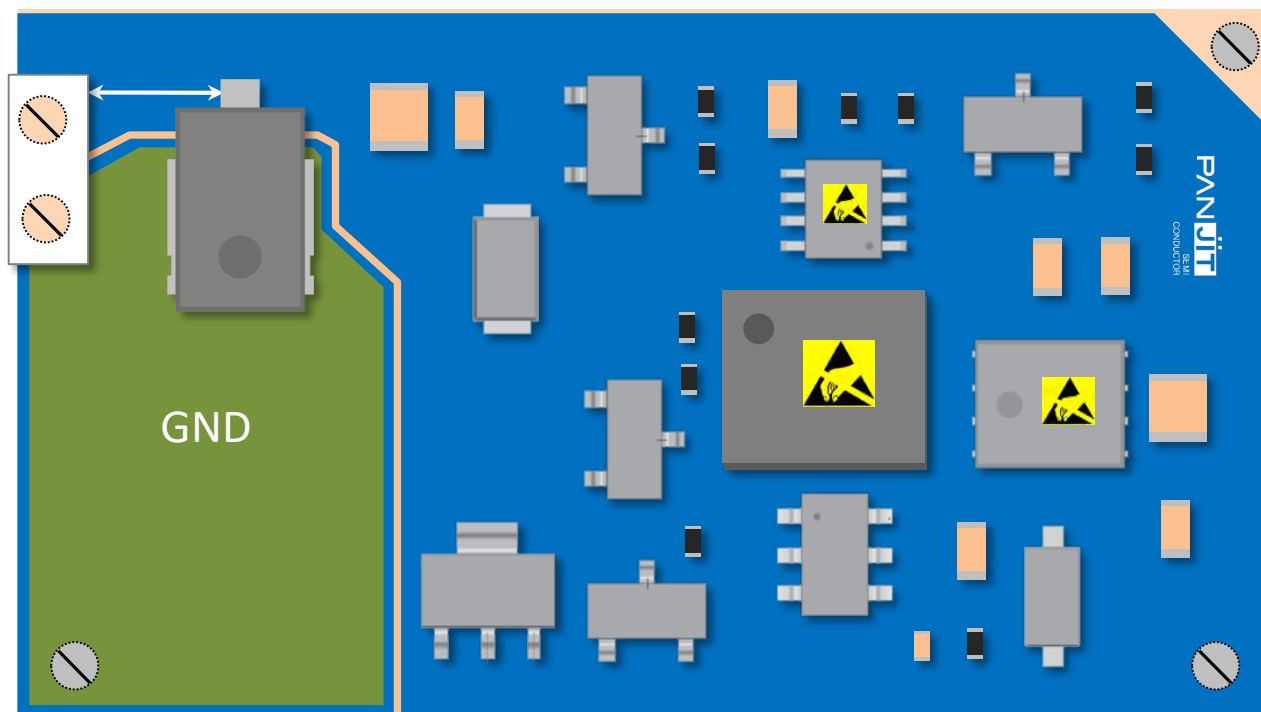



# Power TVS

## For ISO 7637-2 & ISO 16750-2 Pulse 5b Load Dump Protection

Parameter	Type of System		ISO 16750-2	ISO 7637-2
	$U_N=12V$	$U_N=24V$	Pulses	Pulses
$U_S$ (V)	$79 \leq U_S \leq 101$	$151 \leq U_S \leq 202$	5 Pulses at intervals of 1min	1pulse
$U_S * V$ (V)	35	65		
$R_i$ ( $\Omega$ )	$0.5 \leq R_i \leq 4$	$1 \leq R_i \leq 8$		
$t_d$ (mS)	$40 \leq U_S \leq 400$	$100 \leq U_S \leq 350$		
$t_r$ (mS)	10 (+0/-5)	10 (+0/-5)		

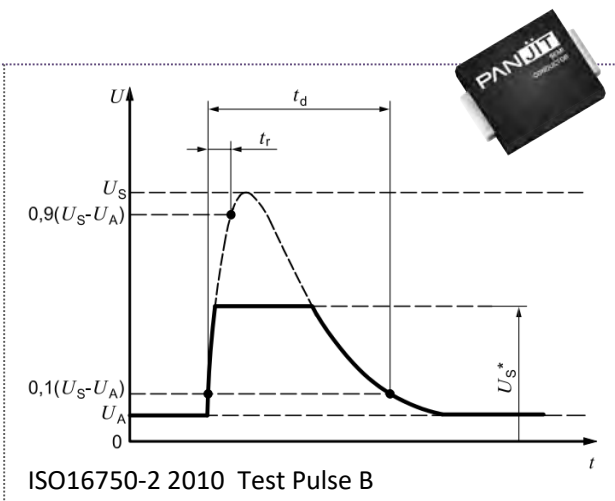

- ISO 16750-2 pulse b replace ISO 7637-2 (2004) pulse 5b.
- ISO 16750-2 pulse b more severe test terms, pulse test times improved from single shocking to 5 times in 5 minutes..
- Suggest to take P6SMBJxxA-AU/1.5SMCJxxA-AU /3.0SMCJxxA-AU/SM5xxA-AU series

TVS series	Package	UNI / BI	$P_D$ (W)	12V System Level IV (V)		24V System Level IV (V)	
				III	IV	III	IV
				30V/ $R_i=4\Omega$ $t_d=40mS$	40V/ $R_i=0.5\Omega$ $t_d=400mS$	50V/ $R_i=8\Omega$ $t_d=100mS$	50V/ $R_i=1\Omega$ $t_d=350mS$
P6SMBJxxA-AU	SMB	UNI / BI	600	PASS	FAIL	FALL	FAIL
1.5SMCJxxA-AU	SMC	UNI / BI	1500	PASS	FAIL	FAIL	FAIL
3.0SMCJxxA-AU	SMC	UNI / BI	3000	PASS	FAIL	FAIL	FAIL
SM5xxA-AU	DO-218AB	UNI	3600	PASS	PASS	PASS	PASS

Notes 12V System recommend TVS  $V_{RWM}$ : 22V/24V/26V/28V; 24V Recommend TVS  $V_{RWM}$ : 30V/33V/36V

# Automotive Grade Power TVS Road Map

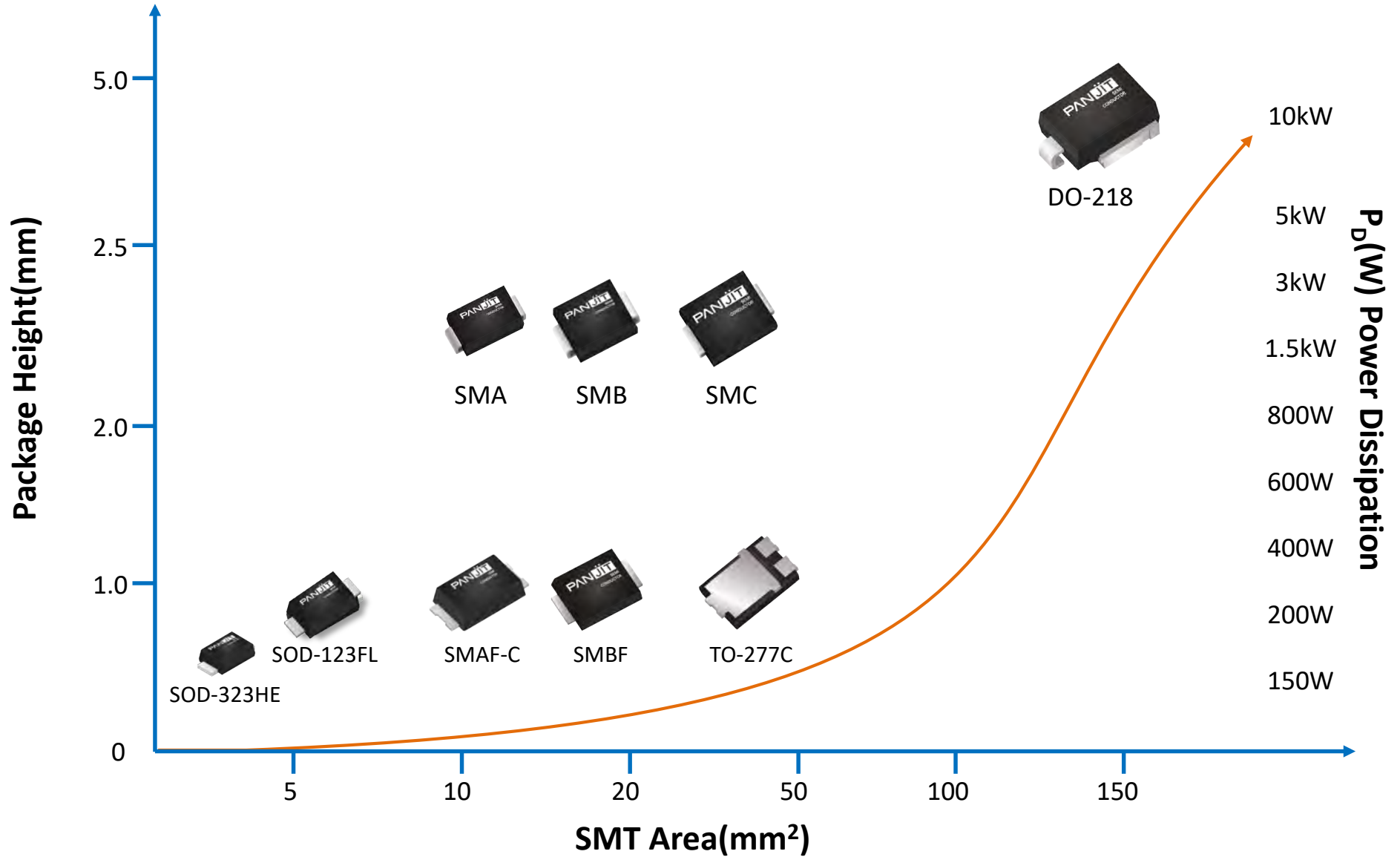

# Data Line Transients Protection

## ESD and Electrical Transient Transmission Protection (ESD Array Solution)

- In-Vehicle Networks: LIN, CAN, FlexRay, MOST, Ethernet
- Multimedia buses: USB, APiX, HDMI, Ethernet



Base on Ethernet structure

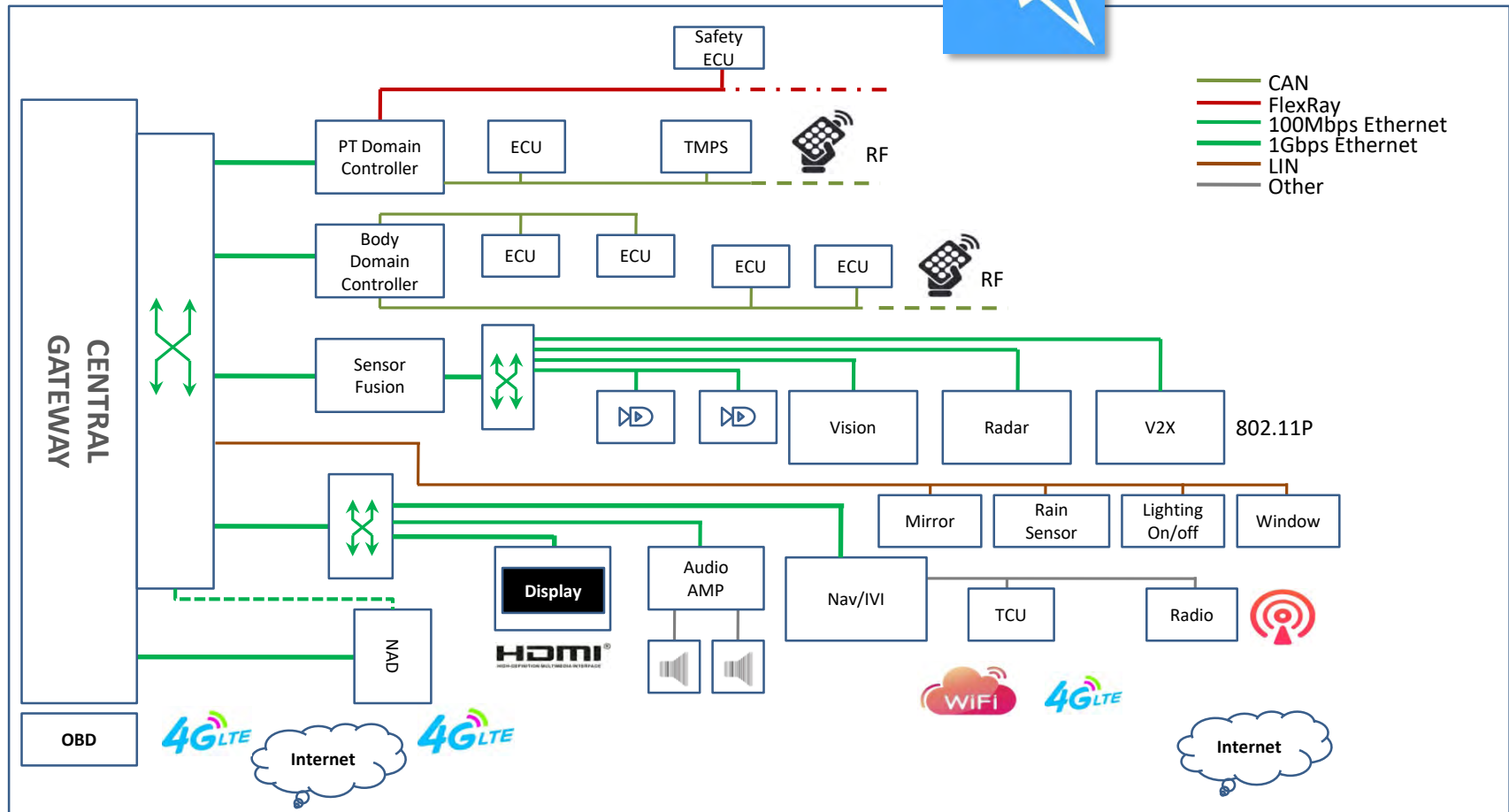

# Automotive Environment Test Levels

## Data Line - ISO 10605 (ESD)

### ISO 10605 Test models and conditions

Application	State	Discharge Position	Discharge Module		ESD Model
			$C_s$ (pF)	$R_D$ ( $\Omega$ )	
ECU	Powered	Inside	330	330	Air & Contact
		Outside	150	330	Contact
ECU	Unpowered	Outside	150	330 or 2000	Air & Contact

### ISO 10605 Test levels

State	ESD Model	Severity test levels				Min. number of pulses
		I	II	III	IV	
Powered	Air (kV)	$\pm 4$	$\pm 6$	$\pm 7$	$\pm 8$	>3
	Contact (kV)	$\pm 4$	$\pm 8$	$\pm 14$	$\pm 15$	
Unpowered	Air (kV)	$\pm 4$	$\pm 6$	--	$\pm 8$	
	Contact (kV)	$\pm 4$	$\pm 15$	--	$\pm 25$	

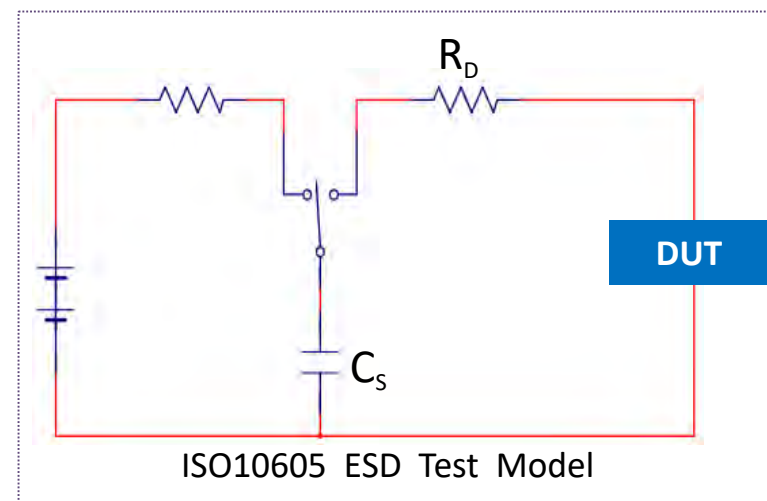



# Automotive Environment Test Levels

## Data Line - ISO 7637-3 (Electrical Transient Transmission)

Test pulse	12V System test pulse severity levels $U_s$ (V)				Test time (Minutes)
	I	II	III	IV	
Fast a (DCC and CCC)	-10	-20	-40	-60	10
Fast b (DCC and CCC)	+10	+20	+30	+40	10
DCC slow +	+8	+15	+23	+30	5
DCC slow -	-8	-15	-23	-30	5
ICC slow +	+3	+4	+5	+6	5
ICC slow -	-3	-4	-5	-6	5

Test pulse	24V System test pulse severity levels $U_s$ (V)				Test time (Minutes)
	I	II	III	IV	
Fast a (DCC and CCC)	-14	-28	-56	-80	10
Fast b (DCC and CCC)	+14	+28	+56	+80	10
DCC slow +	+15	+25	+35	+45	5
DCC slow -	-15	-25	-35	-10	5
ICC slow +	+4	+6	+8	+10	5
ICC slow -	-4	-6	-8	-10	5

# Data Line Transient Surge Protection

## In-Vehicle Networks

- **LIN (Local interconnect Network)** is a low speed serial communication networks. Mainly applied on diver assistant, auto-door lock and door windows or other communication sensors such as, light sensor of the automatic headlight and rain sensor of the automatic wipers.
- **CAN (Controller Area Network)** is a high speed serial communication network which is the most popular network. Mainly used on controller module such as ABS system, engine management system and power control.
- **FlexRay** is a super fast serial communication network. The data speed is faster then 20Mbit/S. Mainly used on engine control, ABS, ECS, SBW.
- **Ethernet (Broad R-Reach)** is a communication network which data transmission speed reaches to 100Mbit/S. This satisfies the high data transfer speed Bandwidth required by intelligent cars. Mainly used on ADAS, panoramic vision detection etc. With the rapid development of connect and smart cars, Ethernet is foreseen to the be the next-generation major communication network.

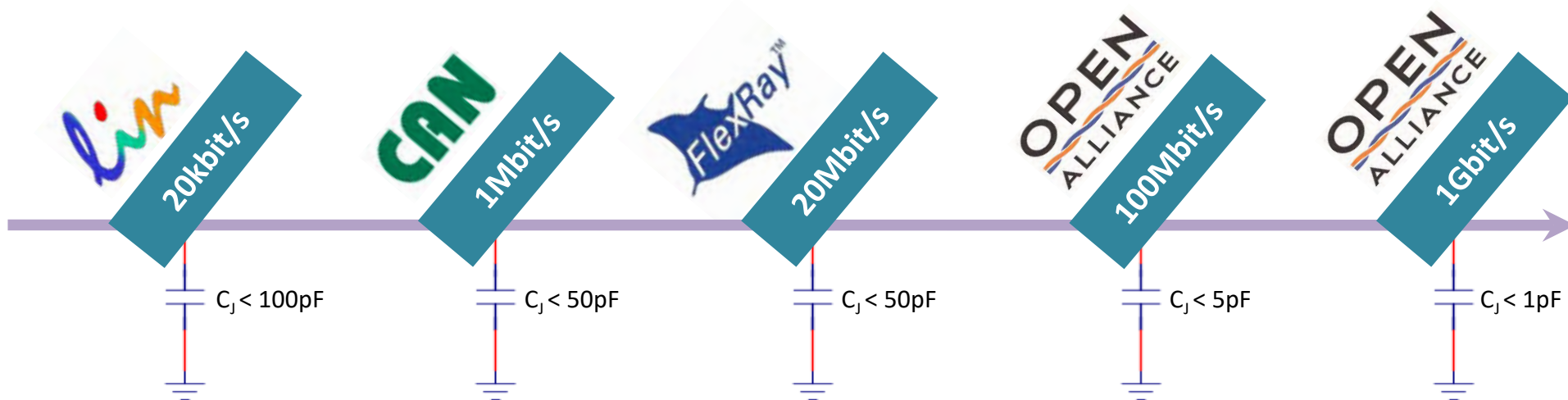

# Data Line Transient Surge Protection

## Multimedia Buses

- **USB2.0** is a common data transfer port with fast transport speed and supports hot plug-in and multiple equipment. The Maximum transmit speed is 480Mbit/S. Mainly used on car charging port, media and software upgrade.
- **LVDS (Low-Voltage Differential Signaling)** is low power consumption, low bit error rate, low crosstalk and low radiation. The data transfer speed can reach 655Mbit/S. Mainly used on video signal transfer, monitor and display port.
- **APIX (Automotive Pixel link)** has the transmit speed that can reach 3Gbit/S. This is mainly used on image transfer, camera and infotainment display.
- **HDMI (High Definition Multimedia Interface)** is a video digitization technology, it can transmit audio and visionary signal at the same time. The transmit speed of HDMI 2.0 can reach to 6Gbit/S, and is used to transit high-definition video and audio to media players.
- **USB type-C** is the latest transmit standard on consumer products, and is starting to used on automobile. The transmission speed can reach 5 Git/s and can also provide fast charging. USB type-C is foreseen to replace USB 2.0 as the standard port on automobile in the future.

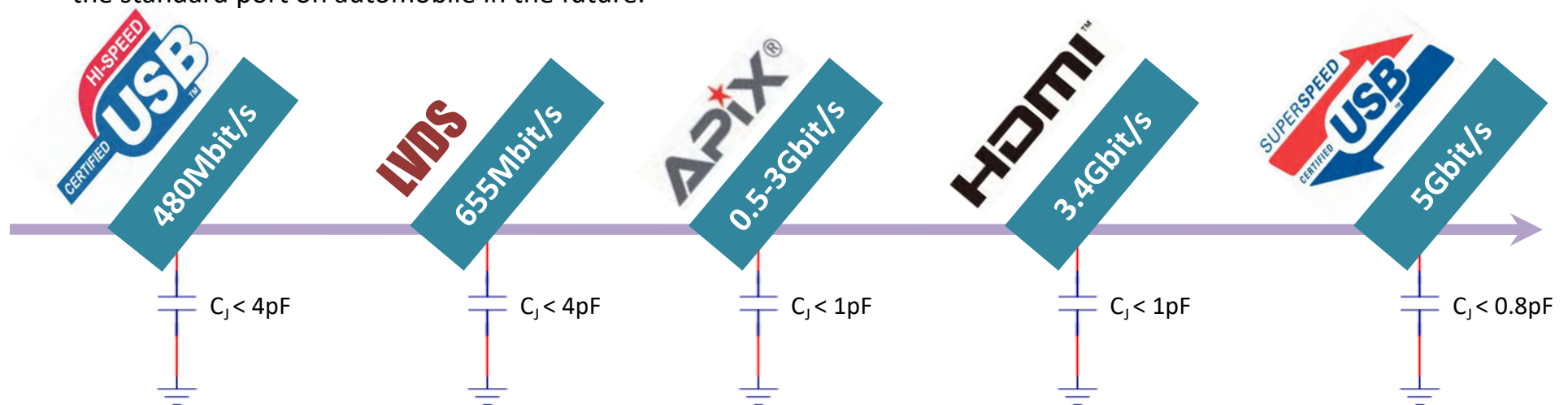

# In-Vehicle Networks ESD Protection

## CAN and LIN Bus

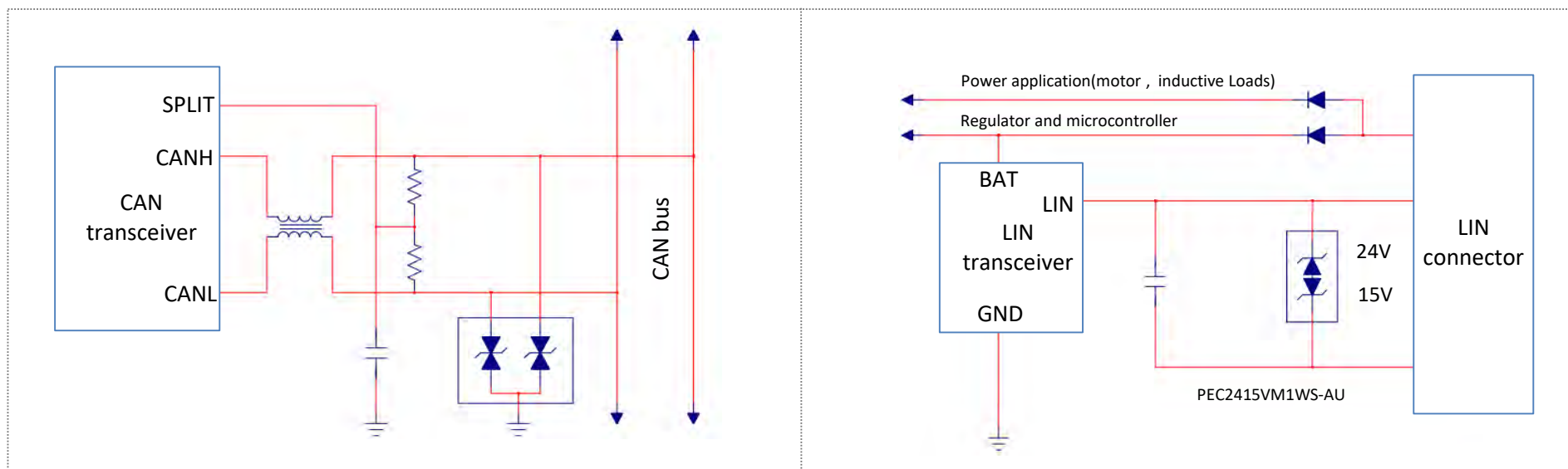

- PANJIT has develop products with series of voltage and package which could be used on CAN bus and LIN bus accordingly. All products complies with IEC-61000-4-2 and ISO 10605 standard and are AEC-Q101 qualified.

### Recommend ESD Array for CAN & LIN



Part Number	UNI / BI	Ch.	$V_{RWM}$ Max. (V)	$V_{BR}$ Min. (V)	$V_{BR}$ Max. (V)	$I_R@V_{RWM}$ nA	$V_C@I_{PP}$ Max.	$I_{PP}$	$C_J$ Max.	Package	Application
PEC3124C2A-AU	BI	2	24	25.4	30.3	50	60	3	15	SOT-23	CAN
PEC3324C2A-AU	BI	2	24	26.2	30.3	50	43	7	30	SOT-23	CAN
PEC3815CS-AU	BI	1	15	16.0	22.5	500	33	4	40	SOD-323	LIN
PEC3824CS-AU	BI	1	24	25.5	35.5	50	45	3	15	SOD-323	LIN
PEC3836CS-AU	BI	1	36	37.5	52.5	50	70	1.5	12	SOD-323	LIN



# In-Vehicle Networks ESD Protection

## FlexRay and Ethernet Bus

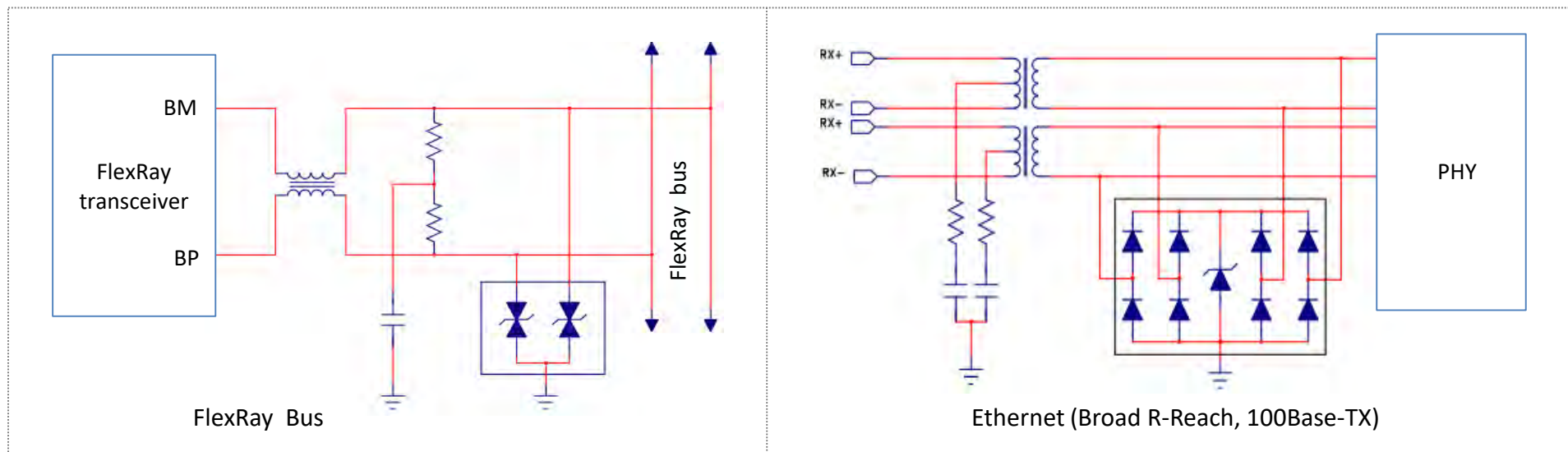

- PANJIT has ESD products with 0.6 pF which could apply on FlexRay and Ethernet application and support transfer speed which exceed 100Mbit.

### Recommend ESD Array



Part Number	UNI / BI	Ch.	$V_{RWM}$ (v)	$V_{BR}$ Min.(V)	$I_R@V_{RWM}$ nA	$V_C@I_{PP}$ Max.(V)	$I_{PP}$	$C_J$ Typ.(pF)	ESD IEC61000-4-2	Package	Application
PEC3824C2A-AU	BI	2	24	26.2	50<	43	7	25	±30KV	SOT-23	FlexRay
PEC3824C2C-AU	BI	2	24	25.4	50<	43	3	17	±30KV	SOT-323	FlexRay
PEC3824C2E-AU	BI	2	24	25.4	50<	43	3	17	±30KV	SOT-523	FlexRay
PE1605C4A6-AU	UNI	4	5.5	6	1000<	15	4	0.6	±20KV	SOT-23 6L	Ethernet

# Multimedia and Infotainment Buses ESD Protection

LVDS, HDMI, USB3.0, APiX

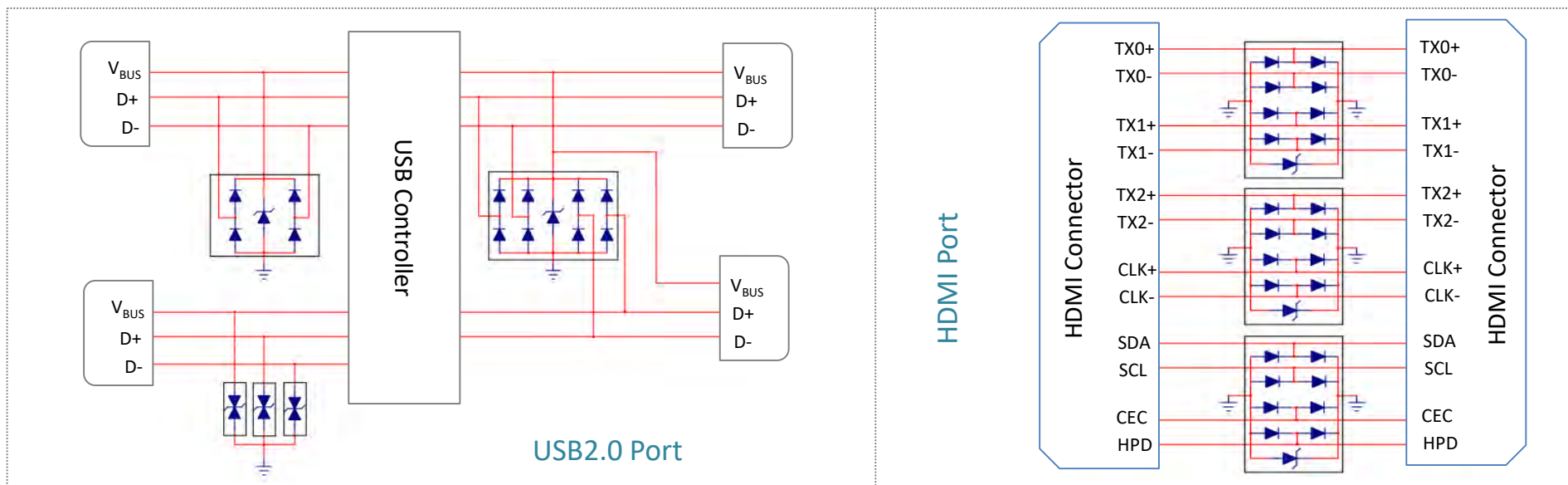

- PANJIT has series of ESD products, which the  $C_j$  is smaller than 0.8 pF, that could apply on high speed data parts such as USB, HDMI, and can support transfer speed exceeding 1Gbit.

## Recommend ESD Array



Part Number	UNI / BI	Ch.	$V_{RWM}$ (v)	$V_{BR}$ Min.(V)	$I_R@V_{RWM}$ nA	$V_C@I_{PP}$ Max.(V)	$I_{PP}$	$C_j$ Typ.(pF)	ESD IEC61000-4-2	Package	Application
PEC1605M1Q-AU	BI	1	5.5	6.8	75	12	1	0.6	$\pm 20KV$	DFN 2L	USB
PJE5V0U8TB-AU	UNI	2	5	5.8	1000	15	4	0.8	$\pm 18KV$	SOT-523	USB
PE1605C4A6-AU	UNI	4	5.5	6	1000	15	4	0.6	$\pm 20KV$	SOT-23 6L	LVDS

# Keys, I/O, Antenna ESD Protection

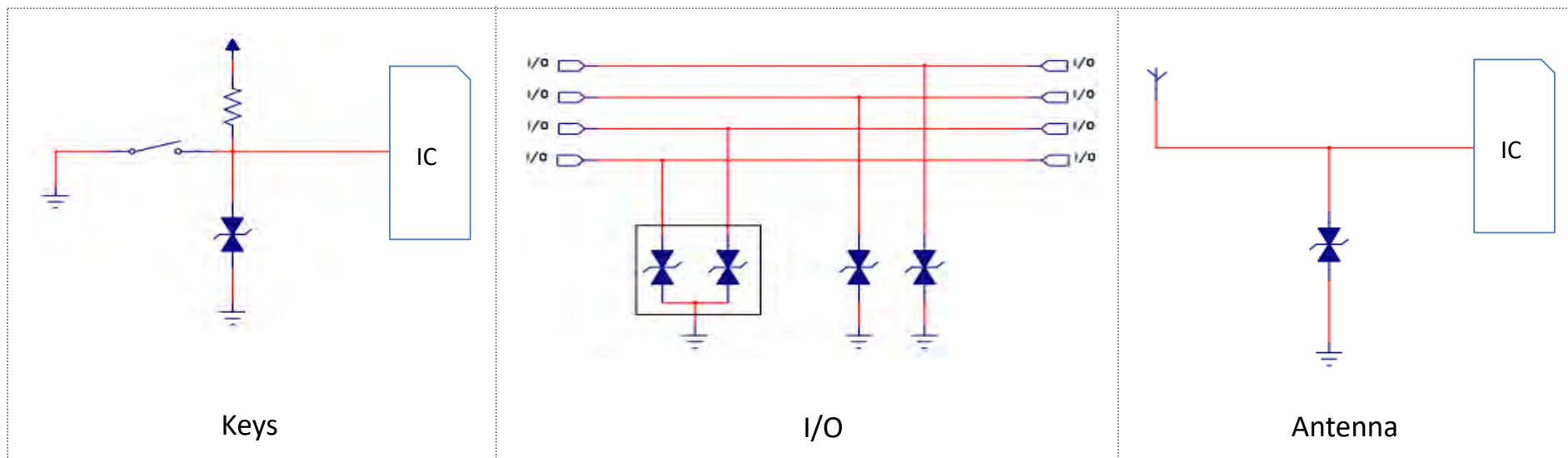

## Recommend ESD Array

Part Number	UNI / BI	Ch.	$V_{RWM}$ (v)	$V_{BR}$ Min.(V)	$I_R@V_{RWM}$ nA	$V_C@I_{PP}$ Max.(V)	$I_{PP}$	$C_J$ Typ.(pF)	ESD IEC61000-4-2	Package	Application
PEC1605M1Q-AU	BI	1	5.5	6.8	75	12	1	0.6	±20KV	DFN 2L	Antenna
PEC3808C2A-AU	BI	2	8	8.5	500	18	8	55	±30KV	SOT-23	I/O
PEC3812C2A-AU	BI	2	12	13	500	27	5	50	±30KV	SOT-23	I/O
PEC3812C2C-AU	BI	2	12	13	500	27	5	50	±30KV	SOT-323	I/O
PEC3812C2E-AU	BI	2	12	13	500	27	5	50	±30KV	SOT-523	I/O

# ESD Technology Evolution

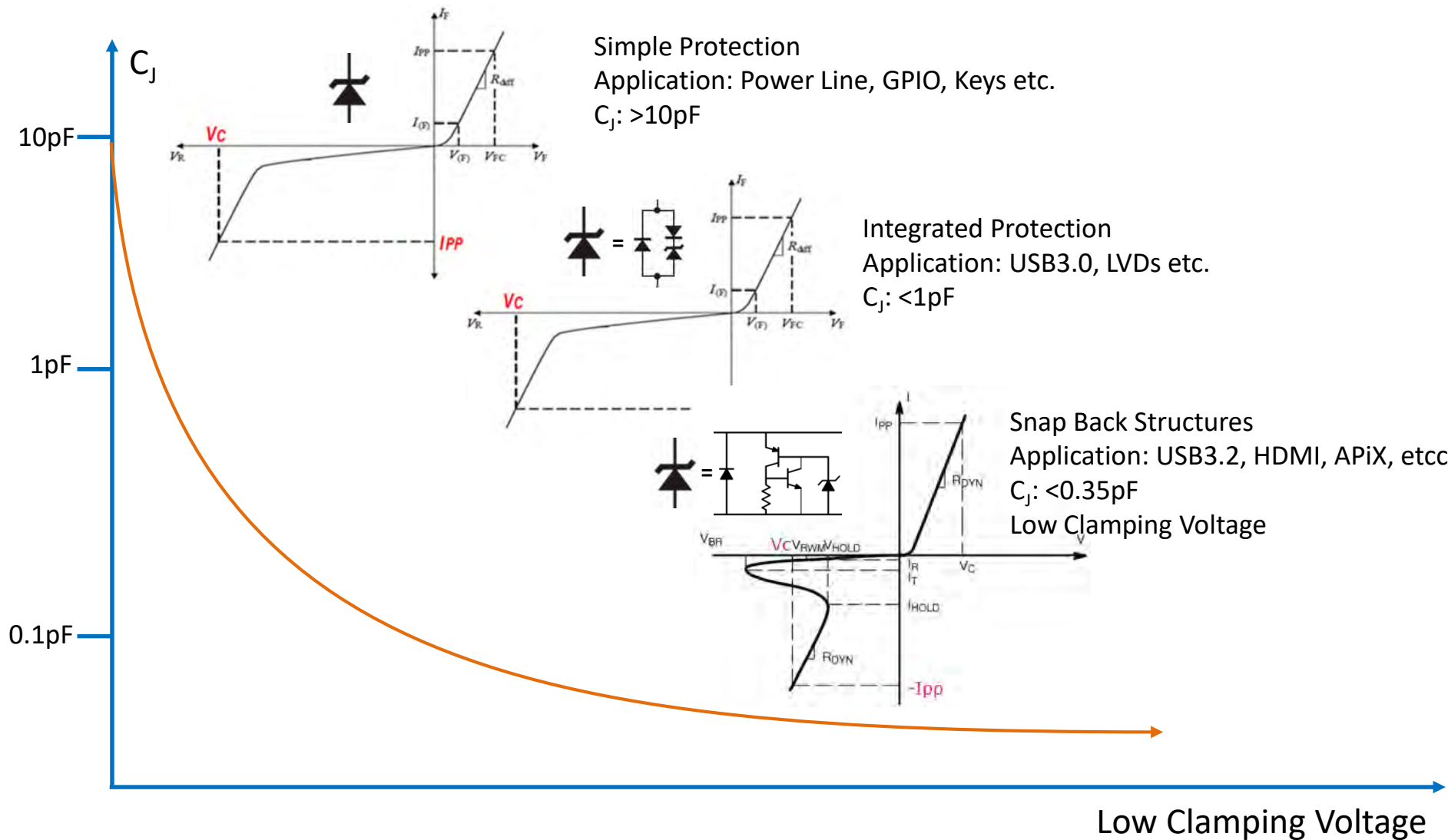





# PANJIT Automotive Solutions

- Motor Control (*Water pump, cooling fan, PV.....*)
- LED Lighting (*front LED lighting, rear and interior LED lighting*)
- Electronic Horn
- New** • USB charger
- New** • Wireless Charging Transmitter

# Automotive Motor Control

*BLDC Motor: Cooling Fan, Oil Pump, Water Pump, Windows Lifter, HVAC etc.*

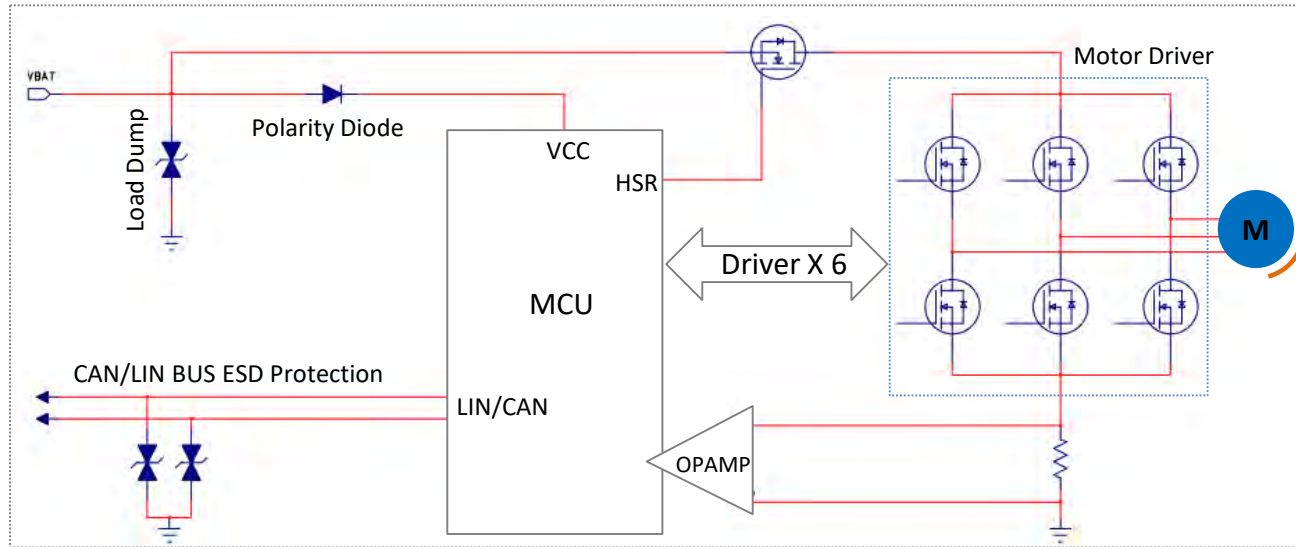

*BDC Motor: Mirror Control, Sunroof, Seat Adjustment, Value Shutters etc.*

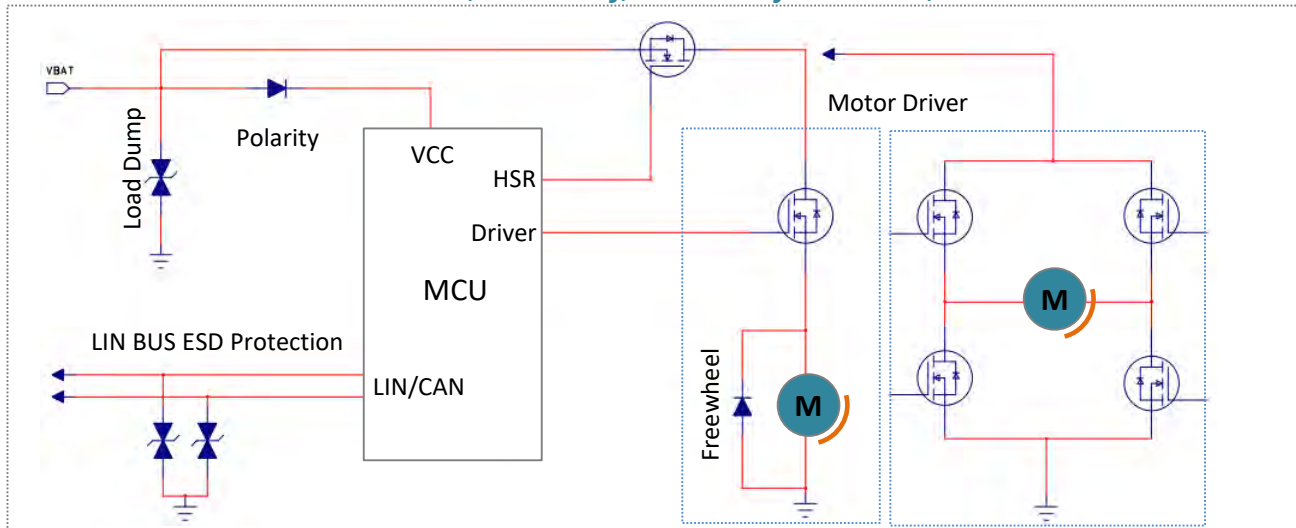

# Solutions for Automotive Motor Control

## Recommend MOSFET for Motor Driver

VDS (V)	VGS (V)	Channel	Rds(on)@10V (mΩ, max.)	Rds(on)@4.5V (mΩ, max.)	TO-252AA	DFN5060-8L	DFN5060B-8L (Dual Channel)	DFN3333-8L
<b>40V Series, for 12V Automotive systems</b>								
40	20	N	32	44	PJD25N04-AU	PJQ5450-AU	PJQ5850-AU	
40	20	N	12	17	PJD40N04-AU	PJQ5448-AU	PJQ5848-AU	PJQ4448P-AU
40	20	N	9.5	13.5	PJD50N04-AU	PJQ5446-AU	PJQ5846-AU	PJQ4446P-AU
40	20	N	6.5	8.5	PJD60N04-AU	PJQ5444-AU	PJQ5844-AU	PJQ4442P-AU
40	20	N	5.5	7	PJD80N04-AU	PJQ5442-AU		PJQ4444P-AU
40	20	N	3.8	5	PJD100N04-AU	PJQ5440-AU		
<b>60V Series, for 24V Automotive systems</b>								
60	20	N	34	40	PJD25N06A-AU	PJQ5468A-AU		PJQ4468AP-AU
60	20	N	21	24	PJD35N06A-AU	PJQ5466A-AU		PJQ4466AP-AU
60	20	N	17	20	PJD40N06A-AU	PJQ5466A1-AU	PJQ5866A-AU	PJQ4464AP-AU
60	20	N	12	15	PJD45N06A-AU	PJQ5462A-AU		

© for 175°C operating junction temperature

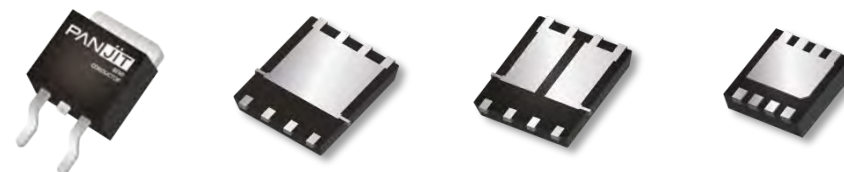



# Solutions for Automotive Motor Control

## Recommend MOSFET in the 2022Y H2 Release

VDS (V)	VGS (V)	Channel	Rds(on)@10V  (mΩ, max.)	Rds(on)@4.5V	DFN3333-8L	DFN5060-8L	TO-252AA	DFN5060B-8L (Dual Channel)
<b>40V(Logic), SGT</b>								
40	20	N	(6.5)/7.8	(9.1)/11.8	PJQ4548P-AU	PJQ5448-AU	PJD30N04S-AU	PJQ5948-AU
40	20	N	(4.2)/5.0	(5.6)/7.6	PJQ4546P-AU	PJQ5446-AU	PJD55N04S-AU	PJQ5946-AU
40	20	N	(2.3)/2.9	(3.0)/3.9	-	PJQ5444-AU	PJD60N04S-AU	-
40	20	N	(1.8)/2.2	(2.4)/3.1	-	PJQ5442-AU	PJD65N04S-AU	-
40	20	N	(1.3)/1.6	(1.6)/2.1	-	PJQ5440-AU	-	-
<b>40V(Standard), SGT</b>								
40	20	N	(9.5)/11	-	PJQ4548VP-AU	PJQ5448V-AU	PJD25N04V-AU	PJQ5948V-AU
40	20	N	5.5	-	PJQ4546VP-AU	PJQ5446V-AU	PJD50N04V-AU	-
40	20	N	(2.95)/3.5	-	-	PJQ5444V-AU	PJD55N04V-AU	-
40	20	N	2.3	-	-	PJQ5442V-AU	PJD06N04V-AU	-
40	20	N	(1.75)/2.1	-	-	PQJ5440V-AU	-	-

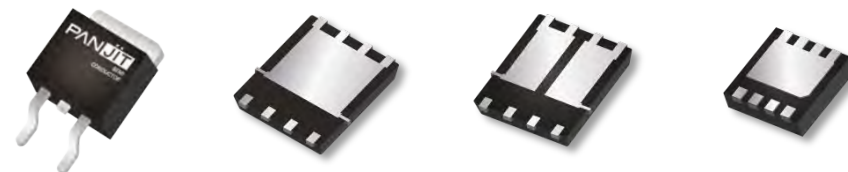

# Solutions for Automotive Motor Control

## Recommend MOSFET in the 2022Y H2 Release

VDS (V)	VGS (V)	Channel	Rds(on)@10V (mΩ, max.)	Rds(on)@4.5V	DFN3333-8L	DFN5060-8L	TO-252AA
<b>30V w/ESD, Standard Trench</b>							
-30	25	P	(15)/18	(23.6)/30.7	PJQ4439EP-AU	PJQ5439E-AU	PJD40P03E-AU
-30	25	P	(12)/14.4	(20)/27	PJQ4437EP-AU	PJQ5437E-AU	PJD45P03E-AU
-30	25	P	(9.7)/11.7	(15.3)/30	PJQ4435EP-AU	PJQ5435E-AU	PJD55P03E-AU
-30	25	P	(6.7)/8	(10.4)/13.5	PJQ4433EP-AU	PJQ5433E-AU	PJD70P03E-AU
-30	25	P	(5.1)/6.1	(8)/10.4	PJQ4431EP-AU	PJQ5431E-AU	PJD90P03E-AU
<b>40V w/ESD, Standard Trench</b>							
-40	25	P	(9.2)/11	22	PJQ4453EP-AU	PJQ5453E-AU	PJD60P04E-AU
-40	25	P	(7.2)/9	20	PJQ4451EP-AU	PJQ5451E-AU	PJD75P04E-AU
-40	25	P	(3.3)/4	6	-	PJQ5449E-AU	-
-40	25	P	(2.5)/3	(3.8)/5	-	PJQ5447E-AU	-

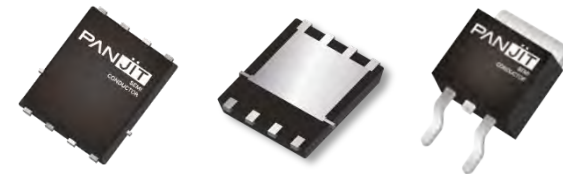



# Solutions for Automotive Motor Control

## Recommend Diodes (TVS, ESD, Rectifier)

Part Number	Type	Specification Description	Package	Application
P6SMBJxxCA-AU	Power TVS	600W/24V/28V/33V /36V Bi-directional TVS	SMB	Transient Protection
PJEC2415VM1WS-AU	ESD Array	Single Channel 24V/15V $\pm$ 30KV LIN Bi-directional ESD	SOD-323	LIN
PEC3324C2A-AU	ESD Array	Dual Channel 24V/ $\pm$ 30KV CAN Bi-directional ESD	SOT-23	CAN
GS1004FL-AU	General Rectifier	1A/400V	SOD-123FL	Polarity
MBR5H60AFC-AU	Power Schottky	5A/60V VF<0.75V	SMAF-C	DC/DC
SB3H60AH-AU	Power Schottky	3A/60V VF < 0.7V	SOD-123HE	DC/DC , Polarity
SS30100HE-AU	Power Schottky	3A/100V VF < 0.8V	SOD-123HE	DC/DC , Polarity
BAS316-AU	Switching	400mW, 100V/250mA Trr < 4nS	SOD-323	Switching



# Automotive LED Lighting

## Front Lighting

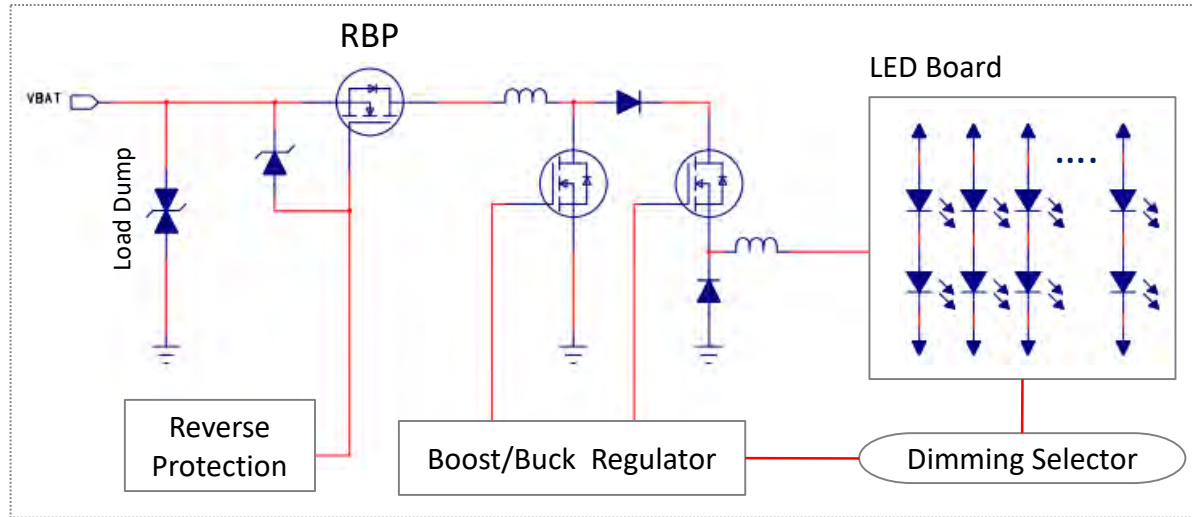

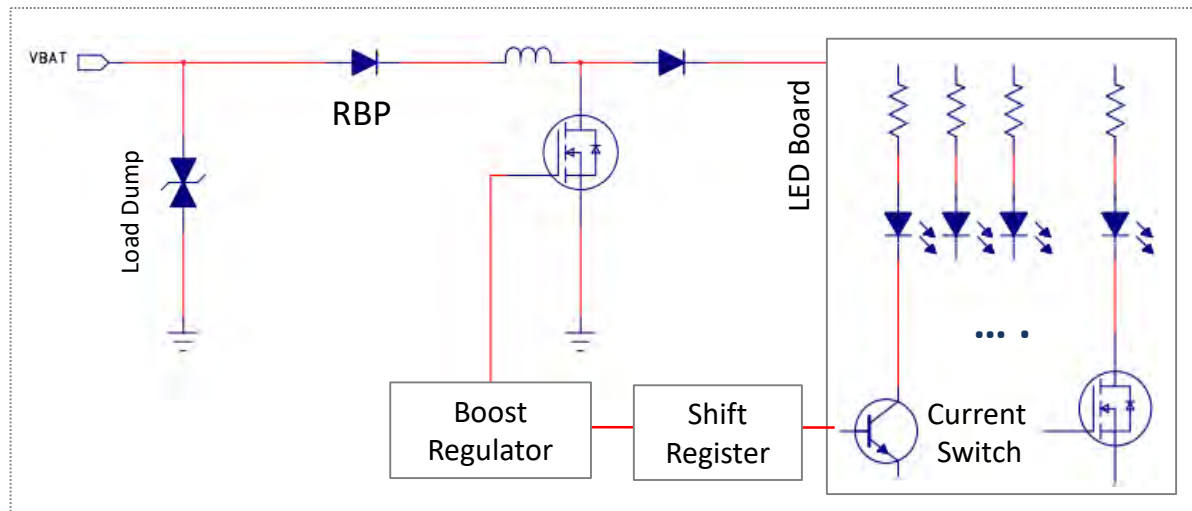

## Rear Lighting and Interior Lighting



# Solutions for Automotive LED Lighting

## Recommend LV & MV MOSFET

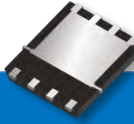
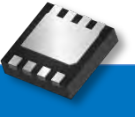
VDS (V)	VGS (V)	Channel	Rds(on) @10V	Rds(on) @4.5V	 SOT-223	 TO-252AA	 DFN5060-8L	 DFN3333-8L	Application
			(mΩ, max.)						
40	20	N	9.5	13.5		PJD50N04-AU	PJQ5446-AU	PJQ4446P-AU	
40	20	N	6.5	8.5		PJD60N04-AU	PJQ5444-AU	PJQ4442P-AU	RBP
40	20	N	5.5	7		PJD80N04-AU	PJQ5442-AU	PJQ4444P-AU	
60	20	N	95	110	PJW4N06A-AU				Current Switch
60	20	N	75	90	PJW5N06A-AU	PJD11N06A-AU		PJQ4460AP-AU	
60	20	N	50	60	PJD16N06A-AU				
60	20	N	34	40		PJD25N06A-AU	PJQ5468A-AU	PJQ4468AP-AU	Buck & Boost
60	20	N	21	24	PJD35N06A-AU PJQ5466A-AU PJQ4466AP-AU				
60	20	N	12	15		PJD45N06A-AU	PJQ5462A-AU		
100	20	N	130	135	PJW5N10-AU	*PJD10N10			Current Switch
100	20	N	50	55		*PJD25N10	*PJQ5474A		
100	20	N	25	28.5	PJD50N10AL-AU PJQ5476AL-AU PJQ4476AP-AU				Boost

\*AEC-Q101 In development

# Solutions for Automotive LED Lighting

## Other Parts Proposals (TVS, ESD, Rectifier, BJT)



Part Number	Type	Specification Description	Package	Application
SMxSxxA-AU	Load Dump TVS	3600W/4600W/6600W 20V-36V Meet ISO16750 5a/5b	DO-218AB	Load Dump
P6SMBJxxCA-AU	TVS	600W/24V/28V/33V /36V Bi-directional TVS	SMB	Load Dump
PJEC2415VM1WS-AU	ESD Array	Single Channel 24V/15V ±30KV LIN Bi-directional ESD	SOD-323	LIN
PEC3324C2A-AU	ESD Array	Dual Channel 24V/±30KV CAN Bi-directional ESD	SOT-23	CAN
MBR5H60AFC-AU	Power Schottky	5A/60V VF<0.75	SMAF-C	Boost
SS1060FL-AU	Power Schottky	1A/60V VF<0.7V	SOD-123FL	Buck
SS2060FL-AU	Power Schottky	2A/60V VF<0.7V	SOD-123FL	Buck
MB3H60AH-AU	Power Schottky	3A/60V VF<0.7V	SOD-123HE	Buck or RBP
BCP56-16-AU	BJT	1A/100V HFE-100-250 NPN Transistor	SOT-223	Current Switch
BCX56-16-AU	BJT	1A/100V HFE-100-250 NPN Transistor	SOT-89	Current Switch

# Solutions for Automotive Electronic Horn

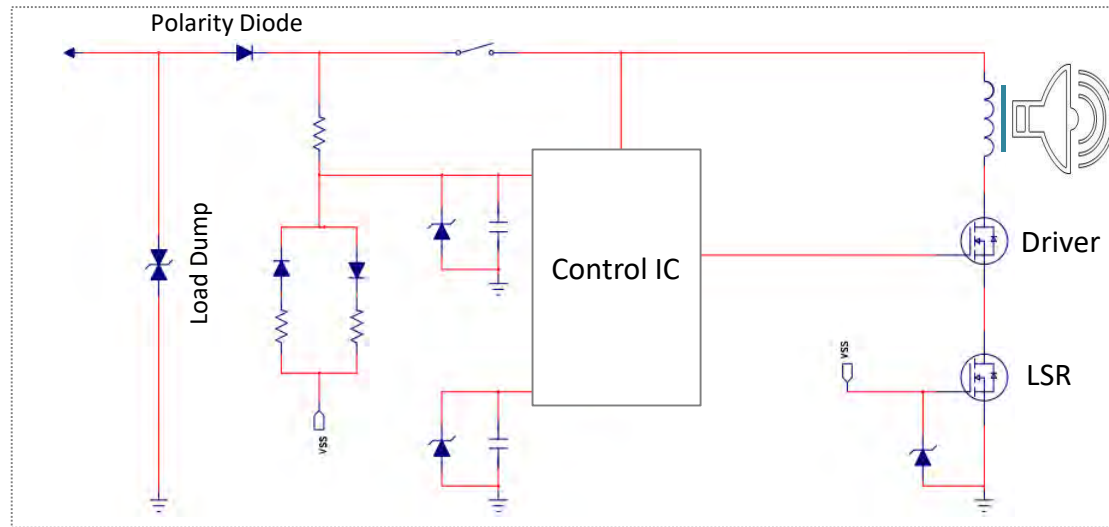

## Recommend MV MOSFET

VDS (V)	VGS (V)	Channel	Rds(on)@10V (mΩ, max.)	Rds(on)@4.5V	TO-252AA	DFN5060-8L	DFN3333-8L	Application
100	20	N	50	55	*PJD25N10	*PJQ5474A		Driver
100	20	N	25	28.5	PJD50N10AL-AU	PJQ5476AL-AU	PJQ4476AP-AU	
30	20	N	7	10	*PJD80N03	*PJQ5410	PJQ4404P-AU	LSR
30	20	N	9	13	*PJD55N03	*PJQ5420	PJQ4408P-AU	

## Recommend Diodes (TVS, Zener, Schottky)

\*AEC-Q101 In development

Part Number	Type	Specification	Package	Application
P6SMBJxxCA-AU	Power TVS	600W/24V/28V/33V /36V Bi-directional TVS	SMB	Transient Protection
MB510-AU	Power Schottky	5A/100V VF < 0.8V	SMC	Polarity
BZT52-Cxx-AU	Zener Diode	500mW 2.4V to 7.5V ±5% Zener Diode	SOD-123	OVP



# Solutions for USB Power Delivery Car Charging

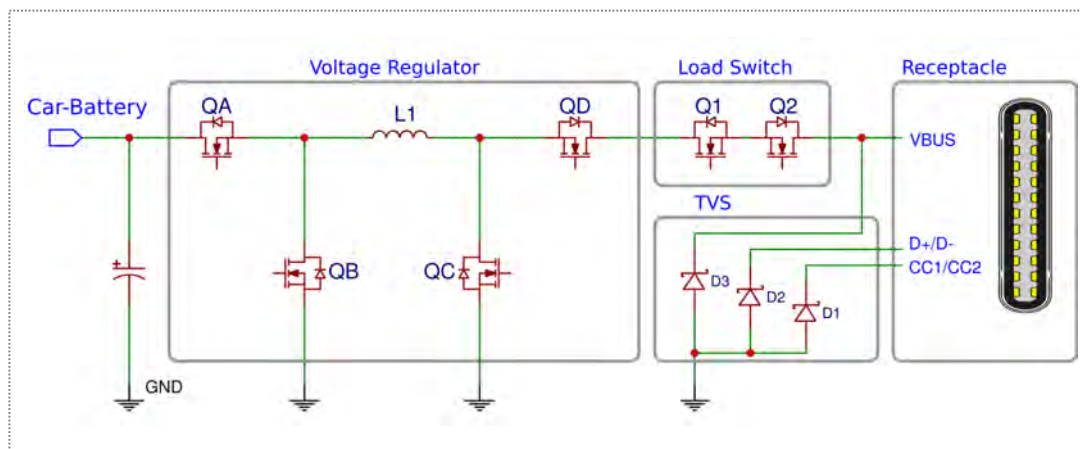

## Recommend LV MOSFET

VDS (V)	VGS (V)	Channel	Rds(on)@10V (mΩ, max.)	Rds(on)@4.5V	DFN5060-8L	DFN3333-8L	Application
30	20	N	3.8	5.5	PJQ5424-AU	PJQ4402P-AU	Load Switch / Voltage Regulator
30	20	N	6	9	*PJQ5410	PJQ4404P-AU	
40	20	N	5.5	7.5	PJQ5442-AU	PJQ4444P-AU	
40	20	N	6.5	9	PJQ5444-AU	PJQ4442P-AU	
40	20	N	9.5	14	PJQ5446-AU	PJQ4446P-AU	

## Recommend Diodes (TVS,ESD Protection )

\*AEC-Q101 In development

Part Number	Type	Specification	Package	Application
PE1605C4E6-AU	UNI	$V_{RWM} : 5.5V, C_j : 0.6pF, ESD : \pm 20KV$	SOT-563	TVS / ESD Protection
PEC1605M1Q-AU	BI	$V_{RWM} : 5.5V, C_j : 0.6pF, ESD : \pm 20KV$	DFN 2L	
P6AFC12A-AU	UNI	$P_{PPM} : 600W, V_{RWM} : 12V, V_c@30.2A=19.9V$	SMAF-C	

# Solutions for Wireless Charging Transmitter

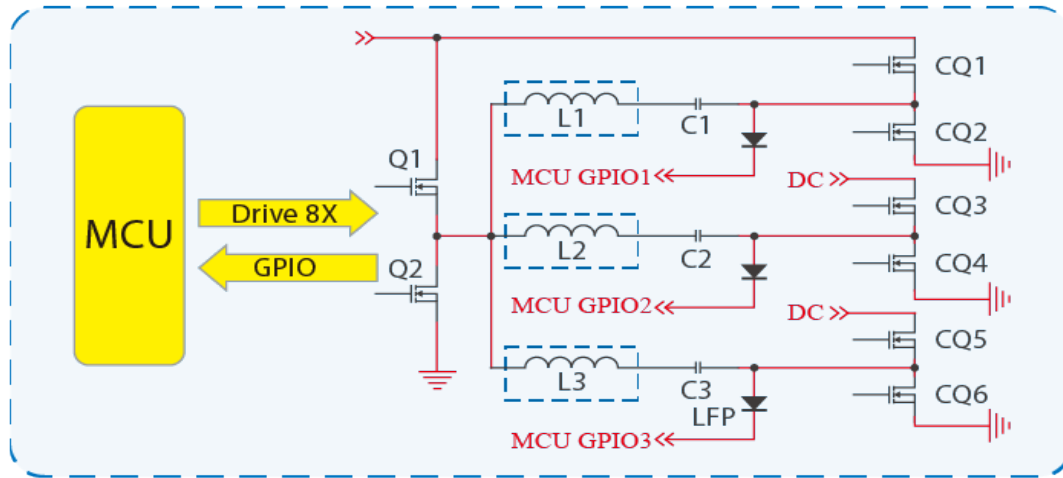

## Recommend Devices

Power Watt	PANJIT Part No.	
	DFN5060-8L	DFN3333-8L
10W-15W	*PJQ5410	PJQ4401P-AU
	*PJQ5412	PJQ4404P-AU
	*PJQ5420	*PJQ4407P
	PJQ5462A-AU	PJQ4408P-AU
	PJQ5466A-AU	*PJQ4410P
	PJQ5466A1-AU	*PJQ4411P
	-	*PJQ4414P
	-	PJQ4464AP-AU
20W-30W	PJQ5424-AU	PJQ4402P-AU

\*AEC-Q101 In development



# Solutions for Engine Control Unit

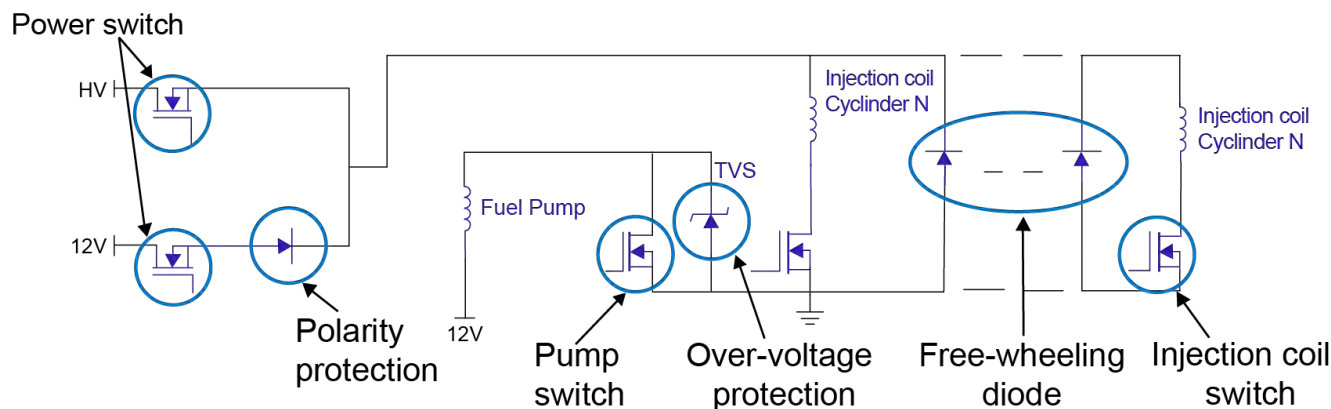

## Recommend Devices

Part Number	Type	Specification Description	Package	Application
P6SMBJ24CA-AU	TVS	600W,24V	SMB	
PJQ5476AL-AU PJD50N10AL-AU	Medium Voltage MOSFET	100V/42A, 25mΩ	DFN5060-8L TO-252	Injection Switch (12V boost)
PJQ5476AL-AU PJD50N10AL-AU	Medium Voltage MOSFET	100V/42A, 25mΩ	DFN5060-8L TO-252	Injector Switch (High side)
PJQ5466A1-AU PJD40N06A-AU	Medium Voltage MOSFET	60V/42A, 17mΩ 60V/40A, 17mΩ	DFN5060-8L TO-252	Injector Switch (Low side)
PJQ5866A-AU	Medium Voltage MOSFET	Dual, 60V/40A, 17mΩ,	DFN5060B-8L	Oxygen Sensor
PEC3124C2A-AU	ESD Protection	24V	SOT-23	ESD Protection

\*AEC-Q101 In development





## xEV Applications

- BMS (Battery Management System)
- xEV Charging Station
- OBC (On Board Charger)

# Solutions for xEV BMS

## Main product

- Power TVS for power line transient surge protection.
- Zener and TVS diode for battery module hot plug-in protection
- Balancer switching MOSFET
- CAN port ESD protection array
- Schottky diodes for DC/DC converter

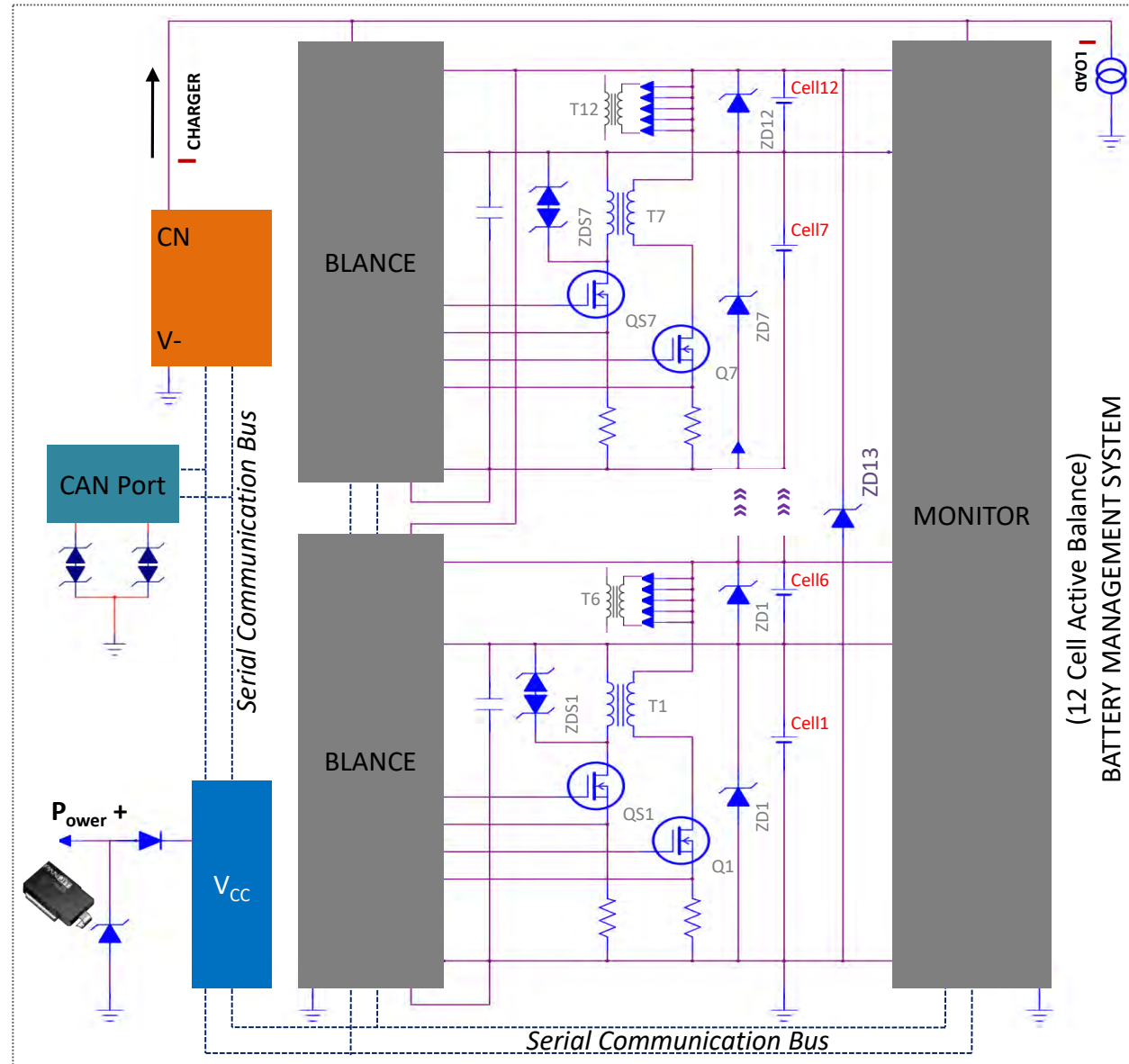



# Recommend Diode for xEV BMS

Part Number	Type	Specification Description	Package	Application
1.5SMCxxA-AU	TVS	22V-36V, 1500W,TVS Pass pulse 5b	SMC	Load Dump
SM8SxxA-AU	TVS	22V-36V ,6600W, TVS Pass pulse 5a,5b	DO-218AB	Load Dump
P4FL5.0A-AU	TVS	400W, 5.0V Ultra Low IR TVS	SOD-123FL	hot plug-in protection
P4SMAJxxA-AU	TVS	400W, 54-75V High Voltage TVS Uni / Bi	SMA	Battery Stack Protection
P6SMBJxxA-AU	TVS	600W, 54-75V High Voltage TVS Uni / Bi	SMB	Battery Stack Protection
P6AFCxxA-AU	TVS	600W, 33-64V Low Profile TVS	SMAF-C	Battery Stack Protection
PEC3124C2A-AU	ESD Array	24V, 180W, $\pm 30$ KV Bidirectional ESD protection	SOT-23	CAN Bus ESD Protection
PEC3324C2A-AU	ESD Array	24V, 300W, $\pm 30$ KV Bidirectional ESD protection	SOT-23	CAN Bus ESD Protection
PEC3215C2A-AU	ESD Array	15V, 150W, $\pm 30$ KV Bidirectional ESD protection	SOT-23	CAN Bus ESD Protection
PZS515V6BCH-AU	Zener	500mW, 5.6V Ultra Low IR	SOD-323HE	hot plug-in protection
PZS515V6BAS-AU	Zener	500mW, 5.6V Ultra Low IR	SOD-123	hot plug-in protection
PZS5112BCH-AU	Zener	500mW, 12V Ultra Low IR	SOD-323HE	MOS G/S ESD Protection
SS1040HE-AU	Power Schottky	1.0A, 40V, $V_F < 0.55$ V	SOD-123HE	DC/DC Converter
SS10100HE-AU	Power Schottky	1.0A, 100V, $V_F < 0.8$ V	SOD-123HE	DC/DC Converter
SS10150HE-AU	Power Schottky	1.0A, 150V, $V_F < 0.85$ V	SOD-123HE	DC/DC Converter
MB510-AU	Power Schottky	1.0A, 40V, $V_F < 0.55$ V	SMC	Polarity Diode
*SRT8100UF	High performance Schottky	8.0A, 100V, $V_F < 0.7$ V	SMBF	Polarity Diode

\*AEC-Q101 In development



# Ultralow $I_R$ Zener for BMS Hot Plug-in Protection

## EPI process Zener advantage

- PANJIT's automotive grade Ultra low  $I_R$  Zener products have extremely low reverse current at high temperature, the reverse current of 5.0V - 6.2V at is  $I_R < 3\mu A @ V_R = 4.2V$
- This series is suitable to protect the port of the BMS from the surge caused by hot plug-in. It can effectively reduce the standby loss of the battery pack and improve the SOC.

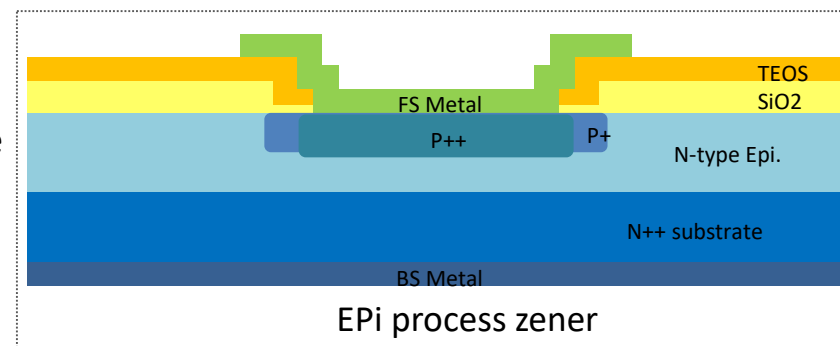

## Ultra Low $I_R$ Zener VS Standard

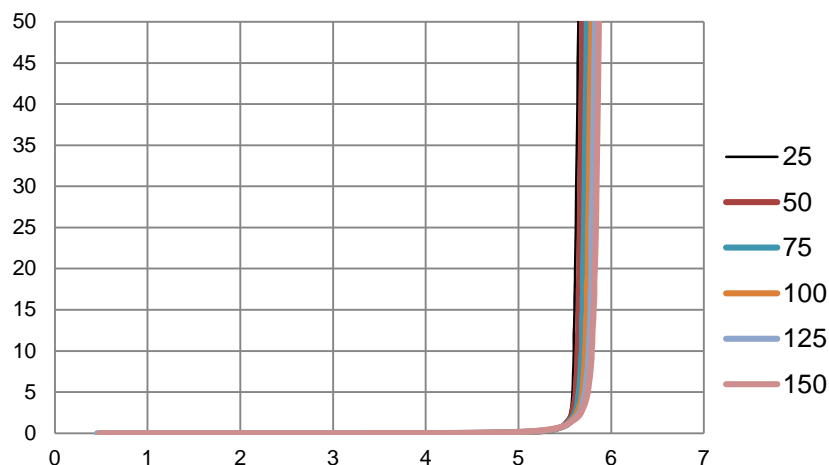

$V_R$ (V)	1.5	2.4	3.3	4.2	5
25° $I_R$ ( $\mu A$ )	0.00	0.01	0.03	1.0	7
125° $I_R$ ( $\mu A$ )	0.00	0.02	0.08	2	20

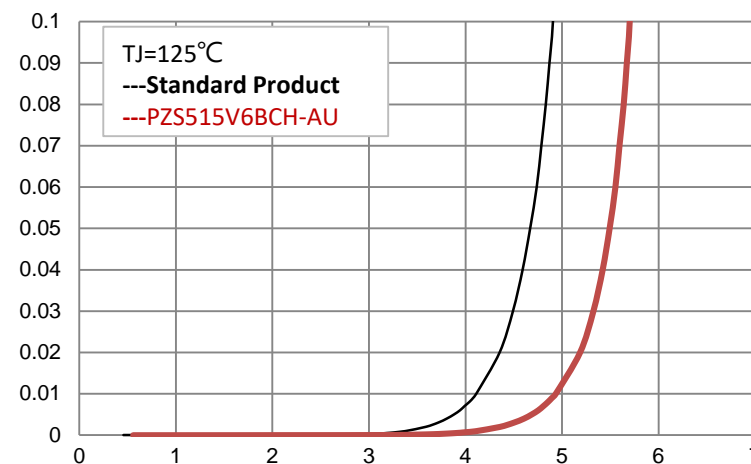

$V_R$ (V)	1.5	2.4	3.3	4.2	5
BZT52-C5V6S-AU ( $\mu A$ )	0.001	0.03	0.7	20	100
PZS515V6BCH-AU ( $\mu A$ )	0.00	0.02	0.08	2	20

# BMS Balancer MOSFET Selection Guide

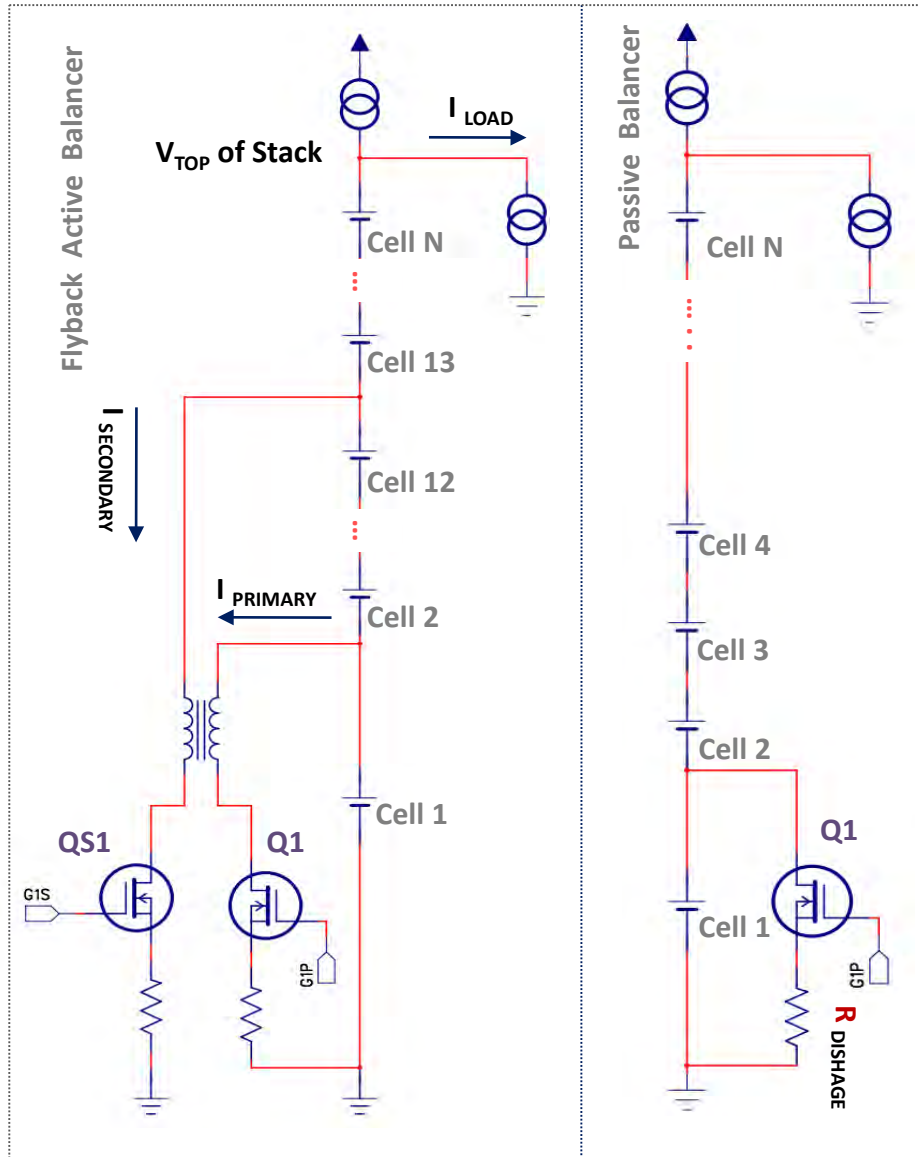

- **How to select MOSFET  $V_{DS}$  for BMS balancer**

- ✓ The MOSFET selection for active balancing is not only based on the balancing current and heat radiation, but also the turns ratio and the power voltage of the stacked battery. These conditions will define the V<sub>DSS</sub> of the primary and secondary and its reliability.

- **Primary MOSFET VDS selection suggestion**

$$V_{DS}(\text{min.}) > V_{CELL} * (1 + \frac{S}{T})$$

- **Secondary MOSFET VDS selection suggestion**

$$V_{DS}(\text{min.}) > V_{CELL} * (T + S)$$

**T:** Turns ratio (primary and secondary)

**S:** The amount of battery stacked on the secondary

- **Passive balancer MOSFET VDS selection suggestion**

- ✓ As for choosing the balancing MOSFET for Passive balancer, the V<sub>DSS</sub> is suggested to be 10% more above the voltage of the stacked battery.

$$V_{DS}(\text{min.}) > V_{CELL} * S * 1.1$$

# LV & MV MOSFET for balancer

VDS (V)	VGS (V)	Channel	Rds(on)@10V (mΩ, max.)	Rds(on)@4.5V (mΩ, max.)	SOT-23	SOT-223	TO-252AA	DFN5060-8L	DFN3333-8L
30	10	N(ESD)		1200	*PJA3428				
50	20	N(ESD)	1600	2500	PJA138K-AU				
50	20	N(ESD)	1450	1950	PJA3438-AU				
60	20	N(ESD)	3000	4000	2N7002K-AU				
<b>Passive Balancer</b>									
30	20	P	110	150	PJA3409-AU				
60	20	P	190	240	PJA3461-AU				
100	20	P	650	700	*PJA3471				
<b>DC/DC, Power Control, Active Balancer</b>									
60	20	N	95	110	PJW4N06A-AU				
60	20	N	75	90	PJW5N06A-AU	PJD11N06A-AU			PJQ4460AP-AU
60	20	N	50	60		PJD16N06A-AU			PJQ4464AP-AU
60	20	N	34	40		PJD25N06A-AU	PJQ5468A-AU		PJQ4468AP-AU
60	20	N	21	24		PJD35N06A-AU	PJQ5466A-AU		PJQ4466AP-AU
60	20	N	17	20		PJD40N06A-AU	PJQ5466A1-AU		PJQ4464AP-AU
100	20	N	310	320	*PJW3N10A	*PJD6N10A			
100	20	N	115	120		*PJD13N10A	*PJQ5472A		
100	20	N	50	55		*PJD25N10	*PJQ5474A		
100	20	N	25	28.5		PJD50N10AL-AU	PJQ5476AL-AU		PJQ4476AP-AU
-60	20	P	110	130	PJW4P06A-AU	PJD14P06A-AU			PJQ5461A-AU
-60	20	P	68	85	PJW5P06A-AU	PJD15P06A-AU			PJQ5463A-AU
-60	20	P	48	65		PJD16P06A-AU			PJQ5465A-AU
-100	20	P	210	230	*PJW3P10A	*PJD10P10A			
-100	20	P	140	170		*PJD14P10A			

\*AEC-Q101 In development

# EV/HEV Charging Model

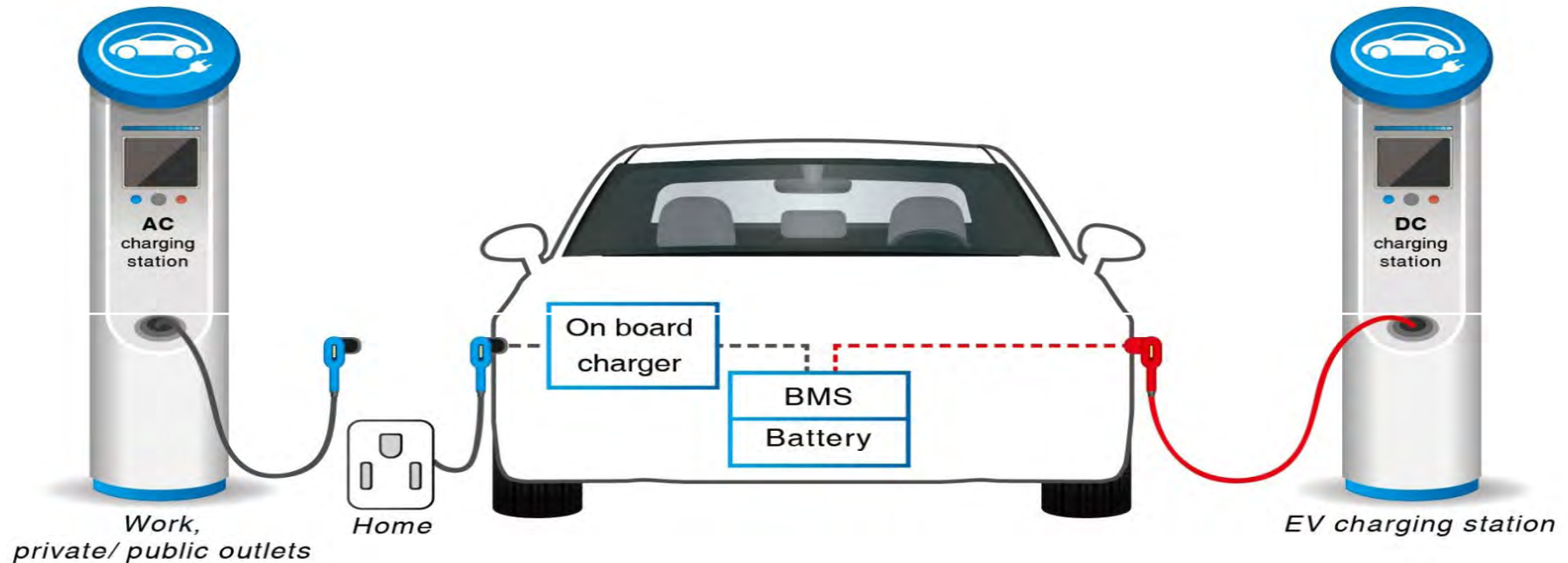

## **AC Charging (Normal Charging)**

The OBC converts to the AC 220V dual phase or AC 380V three phase power to DC power to charge the batter pack. This is mainly use to charge the car at home, the office or parking lots. The OBC power is 3.3KW/6.6KW which is more time consuming.

## **DC Charging (Fast Charging)**

The battery pack is charged directly through a charging station that is constructed by multiple AC power module (10KW-20KW) and which the power is above 60KW. The charging speed is 4-10 times faster than AC charging. Mainly used in larger charging stations.



# EV/HEV Charging System

## EV/HEV Charging System Block Diagram

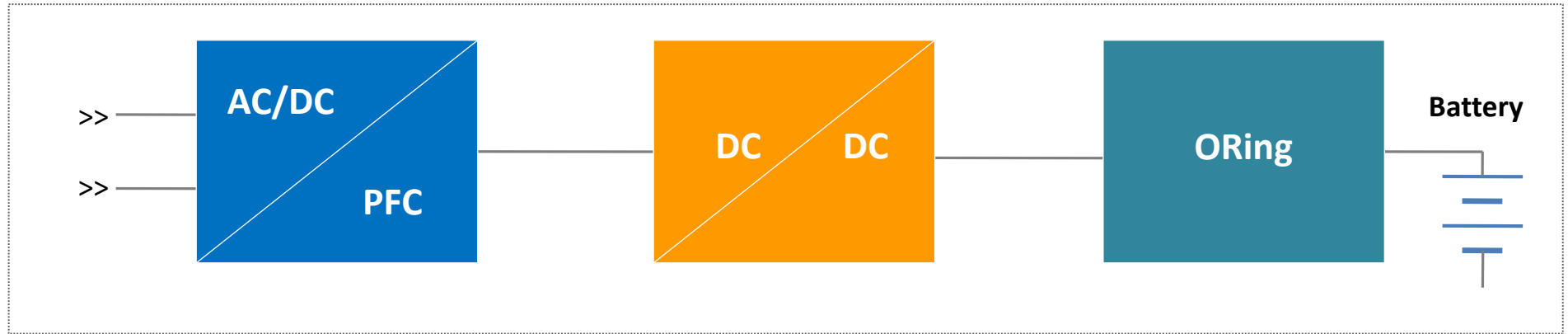

- 600V/1000V/1200V PSDxxxxxx1 series FRED
- 650V/1200V SiC Schottky

- 600V/1000V/1200V QRT series FRED
- 650V/1200V SiC Schottky

- GBJ series power Bridge

# EV/HEV Charging Station

## EV Charging Station Block Diagram

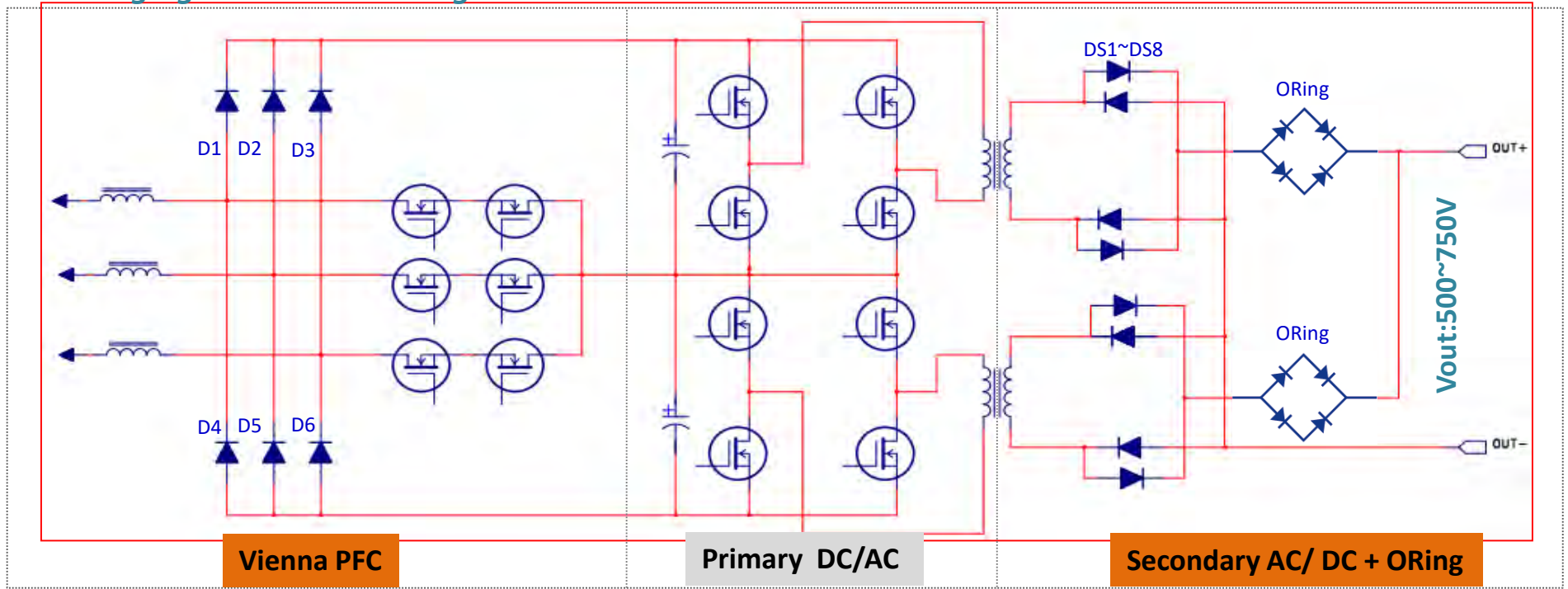

Application-AU	Type	Part Number	Rating	Package	Ref.
Vienna PFC	FRED	PSDH30120S1	30A/1200V	TO-247AD 2LD	D1-D6
		PSDH60120S1	60A/1200V	TO-247AD 2LD	
Secondary AC/DC	FRED	PSDP3060S1	30A/600V	TO-220AC	DS1-DS8
		PSDH3060S1	30A/600V	TO-247AD 2LD	
		PSDH6060S1	60A/600V	TO-247AD 2LD	
ORing Diode	Bridge	*GBJ3510	35A/1000V	GBJ	ORing

\*AEC-Q101 In development

# EV On Board Charger

## EV/HEV On Board Charger Block Diagram

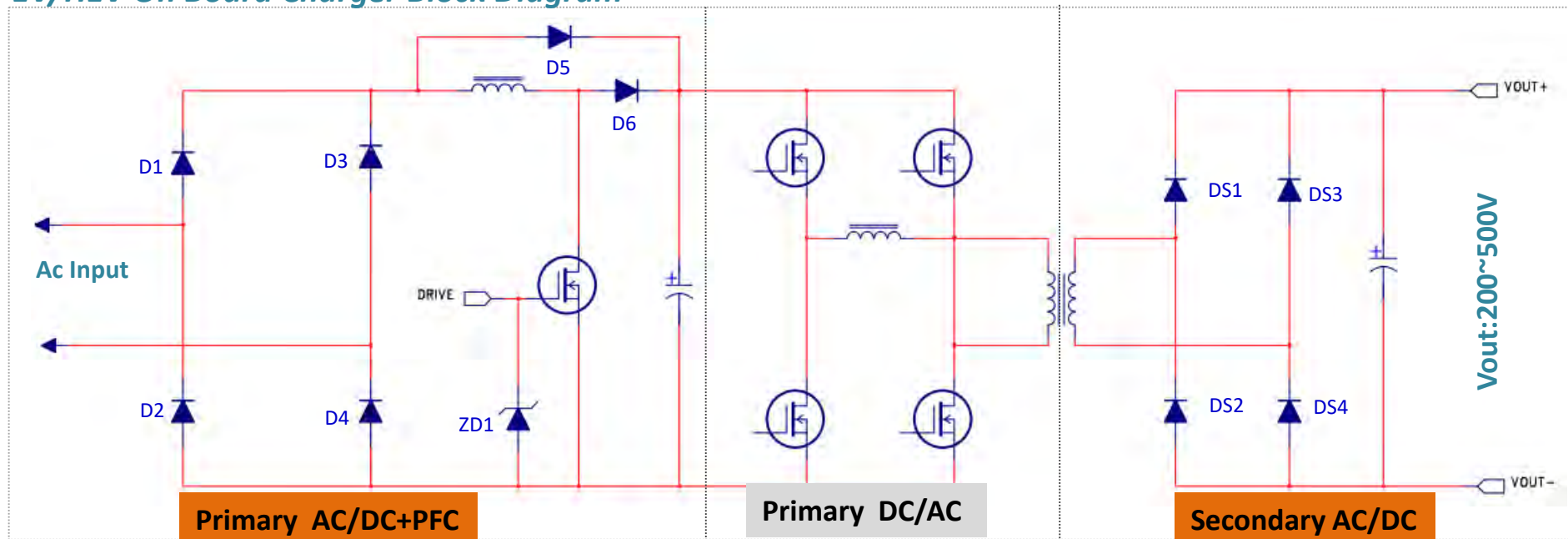

Application-AU	Type	Part Number	Rating	Package	Ref.
PFC	SiC Diodes	*PCDP1065G1	10A/650V	TO-220AC	D6
PFC MOSFET Protection	Power TVS	P4SMAJ15CA-AU	400W/15V	SMA	ZD1
Secondary AC/DC	FRED	*PSDP3060S1	30A/600V	TO-220AC	
		*PSDH3060S1	30A/600V	TO-247AD 2LD	DS1-DS4
		*PSDH6060S1	60A/600V	TO-247AD 2LD	

\*AEC-Q101 In development

# Quality Management Systems



PANJIT's well-established Quality Management Systems allows the company to collaborate efficiently and structurally manage its quality-related activities in order to provide its customers with defect-free products and services at the right time.

The QMS engages its employees in creating values for themselves and therefore to our customers.

# Automotive Quality

- **AUTOMOTIVE QUALITY PRINCIPLES**

At Panjit, Quality is an integral part of the entire product life cycle which begins from product conceptualization to manufacturing and to other associated services. That is why we drive continuous improvement in our processes , building Quality in the manufacturing floors, laboratories and offices.

- **International Standards Certification**

Our manufacturing sites that produce automotive products are certified to IATF 16949 and OHSAS 18001 thus ensuring our workforce is protected while producing products of the highest quality and reliability.

- **Product and Process Development**

The key to deliver reliable and superior products are using robust design practices and world-class process control. Our APQP process adopts a structured approach from product design to qualification. PANJIT focuses on prevention at the design stage and best practice standardization on mass production.

- **Automated processes and dedicated people**

The manufacturing processes are equipped with best-in-class equipment, automated systems and controlled by our highly skilled employees. The performance at every stage of the process is monitored electronically to ensure process stability in order to meet our goal of zero-defect product.

- **Quality Mindset**

All employees are expected to act as quality advocates at their respective area. We are sensitive to abnormality and engage teams to detect the underlying root cause and implement robust solutions. Thus, the Quality mindset of 'ZERO DEFECT' is ingrained throughout the whole organization.



# PANJIT Quality Milestones

Through the years, PANJIT continuously upgrades the quality and sustainability management systems in order to keep its promise of delivering defect-free product to customer through engaged workforce with zero impact to environment.

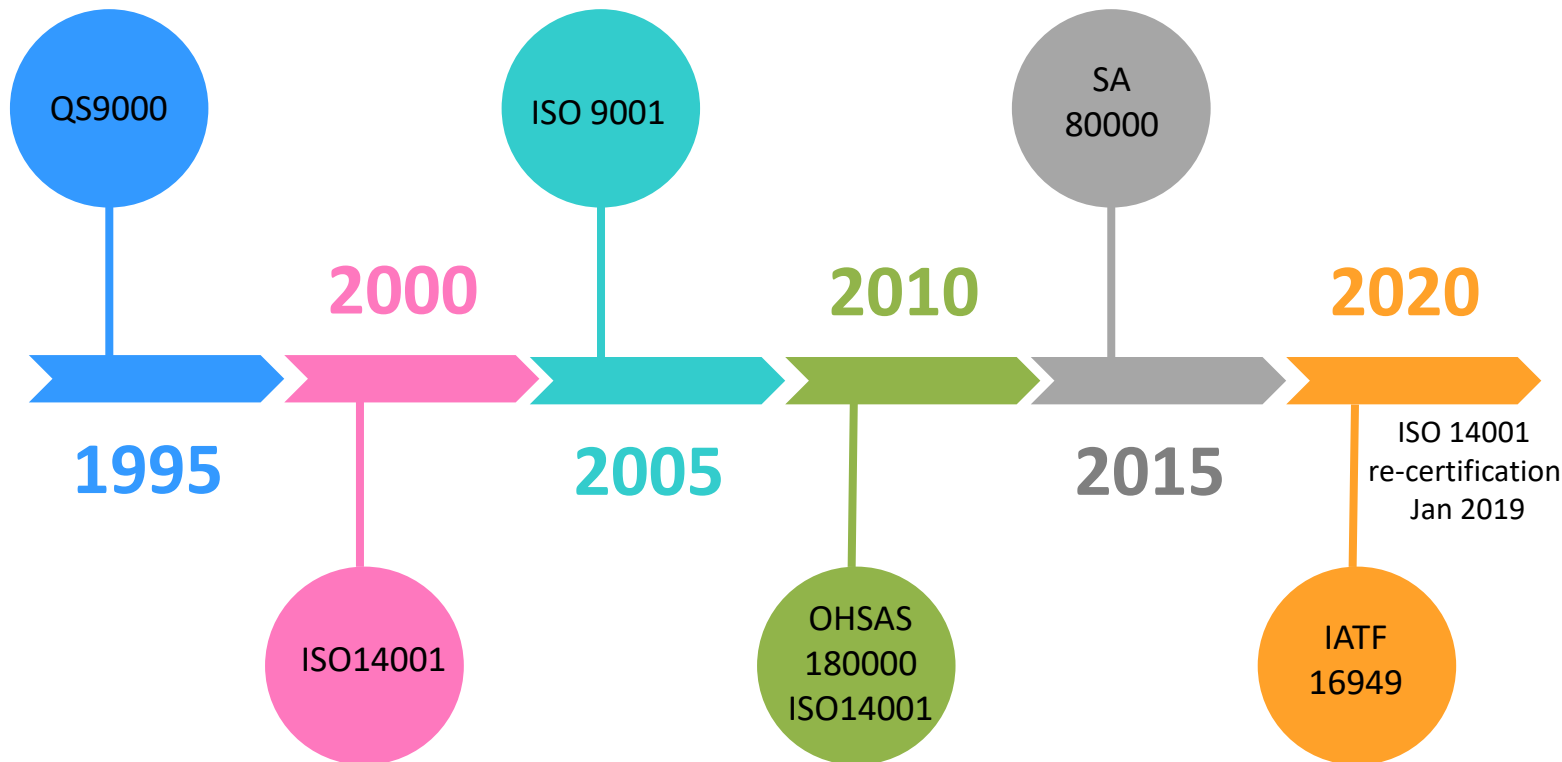

\* The above certifications is for PANJIT Gangshan but equivalent quality roadmap is available for Pynmax and PANJIT Wuxi as requested.

## PANJIT official account



[www.panjit.com](http://www.panjit.com)



LinkedIn



WeChat



facebook

## E-commerce platform



Digi-Key  
ELECTRONICS



M Mouser  
ELECTRONICS



RUTRONIK 24  
next generation e-commerce



TECHDesign



Thank You

**YOUR COMPONENT . OUR PROFESSION**