

Automotive ESD Protection

AEC-Q101 Qualified ESD Devices for Network Transceivers

AEC-Q101 Qualified



► Key Features

- Bi-directional high ESD robustness up to 30kV
- Excellent ESD clamping behavior
- Low device capacitance
- Package miniaturization
- AEC-Q101 qualified

► Target Applications

- ECU
- Lighting control
- Passenger seat module
- Instrument panel



► Compliant with ISO 10605

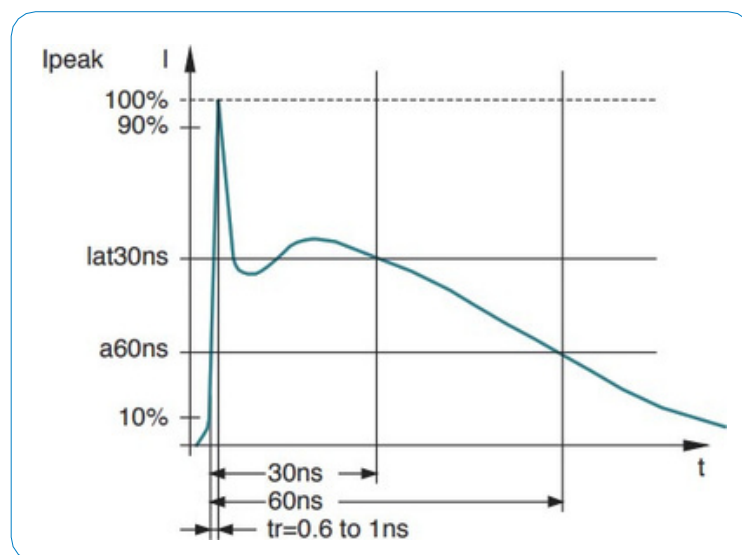

➤ Capacitance matches 20 Kbit/s – 10 Mbit/s

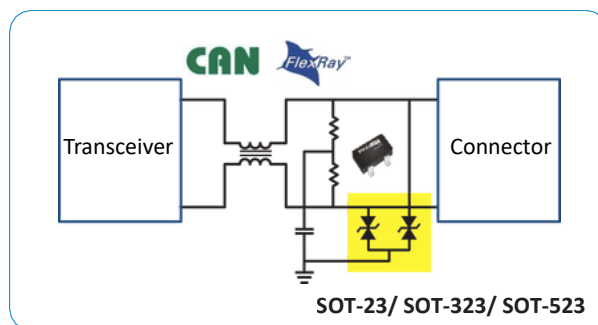
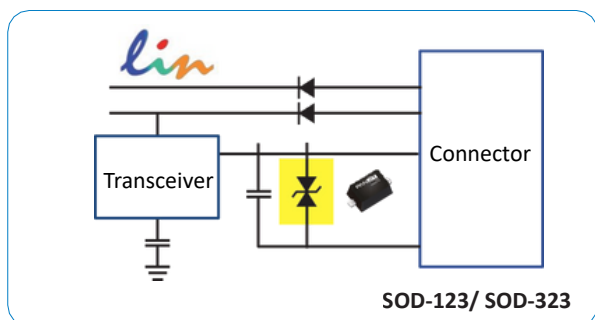
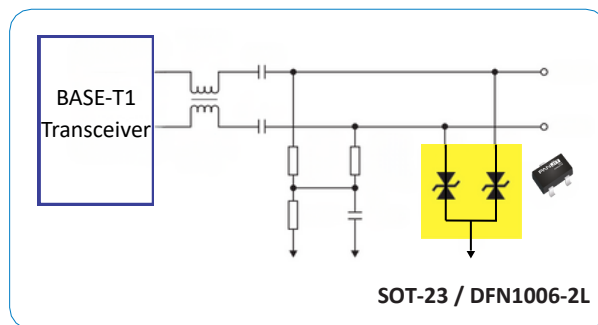
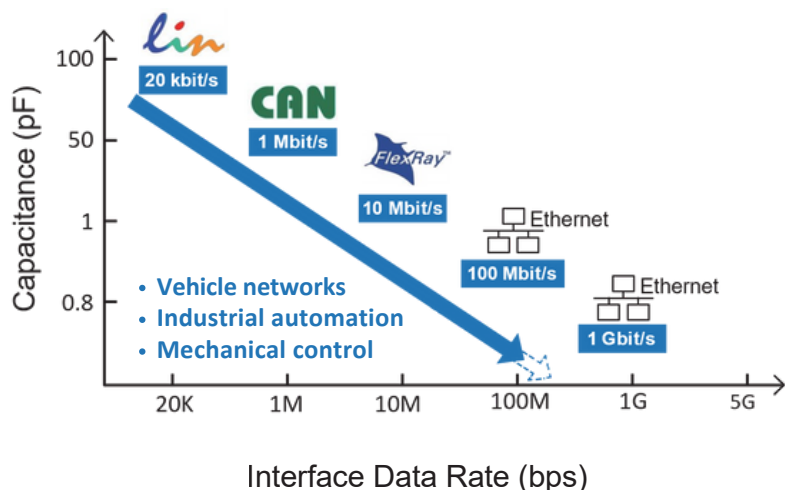

➤ Products

Application	Power System	Channel	V_{RWM}	Part Number	Package
	V		V		
LIN BUS	12 / 24	1	24	PEC3824AS-AU	SOD-123
		1	24	PEC3824CS-AU	SOD-323
CAN BUS	12	2	24	PEC3824C2A-AU	SOT-23
		2	24	PEC3824C2C-AU	SOT-323
		2	24	PEC3824C2E-AU	SOT-523
	24	2	36	PEC3836C2A-AU	SOT-23
		2	36	PEC3836C2C-AU	SOT-323
		2	36	PEC3836C2E-AU	SOT-523
	48	2	48	PEC3848C2A-AU	SOT-23
		2	54	PEC3854C2A-AU	SOT-23
2	72	PEC3872C2A-AU	SOT-23		
Ethernet	12 / 24	1	24	PEC22SD24C2A-AU*	SOT-23
		2	24	PEC22SD24M1Q-AU*	DFN1006-2L
	48	1	48	PEC22SD48C2A-AU*	SOT-23
		2	48	PEC22SD48M1Q-AU*	DFN1006-2L

*Under development